

PRIME DESIGN™

A Safe Fleet Brand

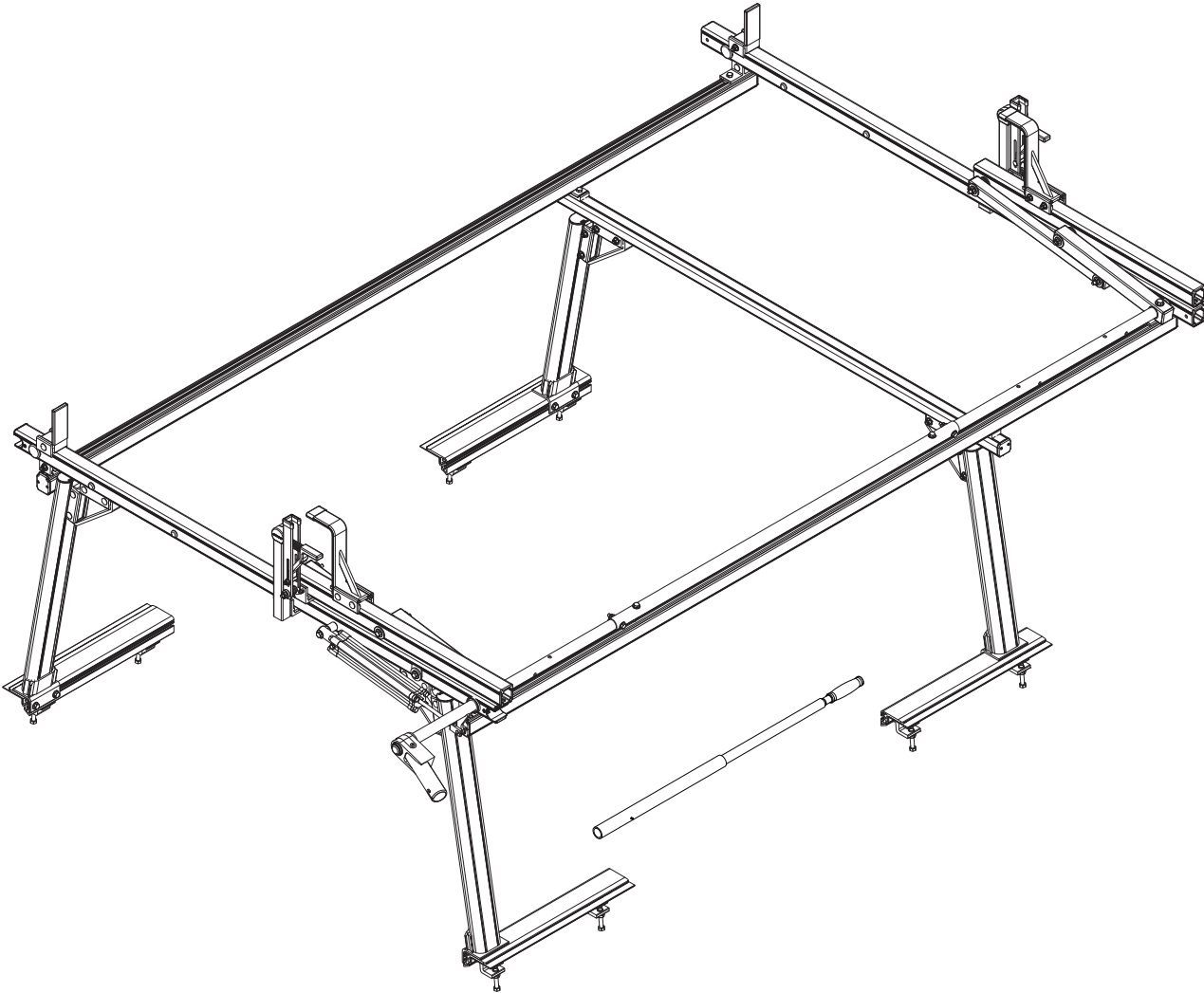

PBR 0021

CONTENTS OVERVIEW

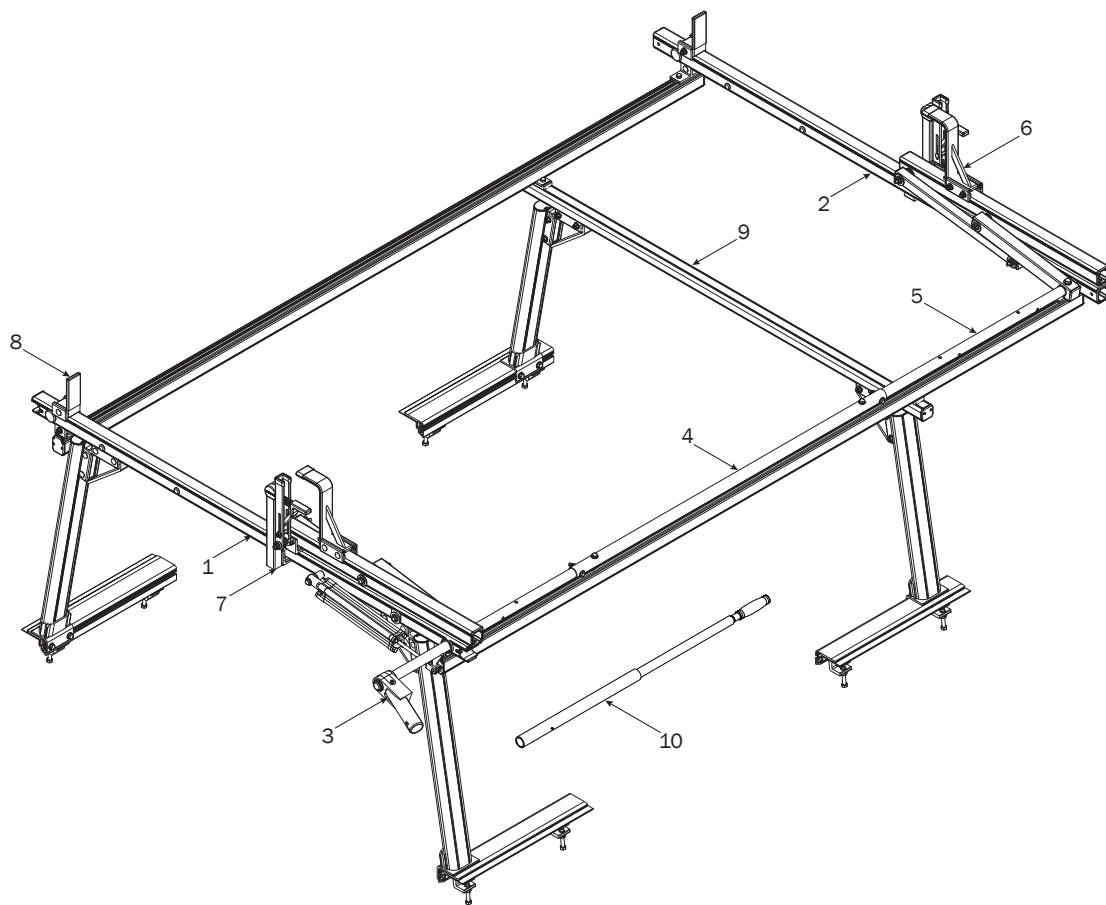

1—Rear Crossbar Assembly..... (Qty 1)

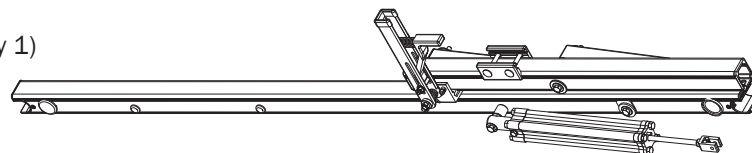

2—Front Crossbar Assembly (Qty 1)

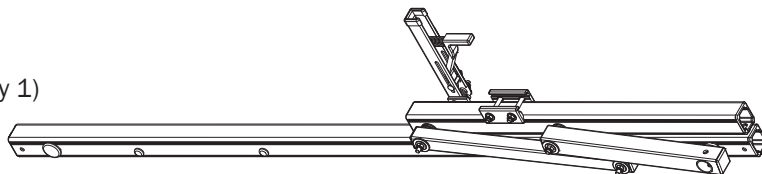

3—Rear Drive Shaft..... (Qty 1)
Right Hand, Ver B5, 34.00”

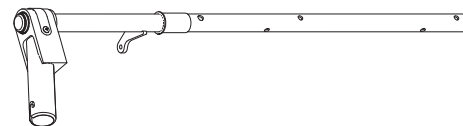

4—Connecting Bar..... (Qty 1)
48.00”

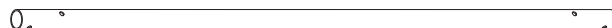

5—Front Drive Shaft (Qty 1)
B Version, 35.75”

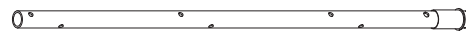

6—Z Post (Qty 2)
Adjustable, 7.25”

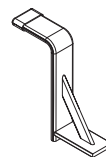

7—L Post (Qty 2)
Gen4, Auto Clamp, 9.25"

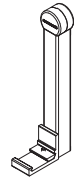

8—Ladder Stop Assembly..... (Qty 2)
1.75"



9—FBM-0062..... (Qty 1)
PTR Suspended ErgoRack Mounting System

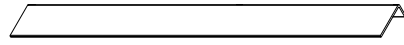

PTR Bed Rail Padding (4X)



PTR Mounting Rail (4X)



Suspension Bars (2X)



G3 Crossbar (1X)

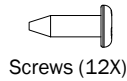

Screws (12X)

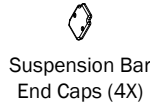

Suspension Bar End Caps (4X)



Crossbar End Caps (2X)



Crossbar Brackets (2X)



Suspension Bar Brackets (4X)



PTR Rack Leg, Front, 23" (2X)



PTR Rack Leg Rear, 28.50" (2X)



PTR Tube Foot Clamp (8X)

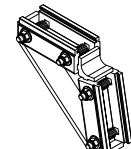

PTR Crossbar/Leg Connector (4X)

10—Removable Handle..... (Qty 1)

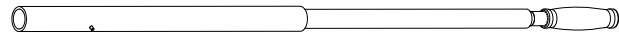

11—HKT-8163-Rotation Hardware Kit (Qty 1)
(Not called out in Overview)



Clevis Pin (1X)

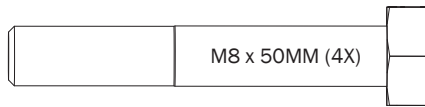

M8 x 50MM (4X)

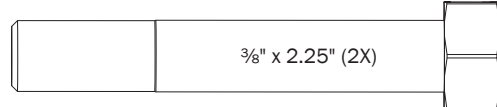

3/8" x 2.25" (2X)

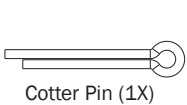

Cotter Pin (1X)

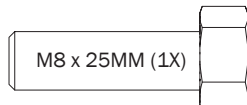

M8 x 25MM (1X)



M8 Lock Nut (5X)

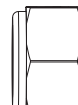

3/8" Lock Nut (2X)

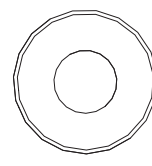

5/16" Flat Washer (10X)

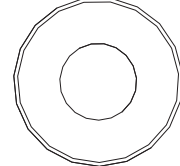

3/8" Flat Washer (4X)

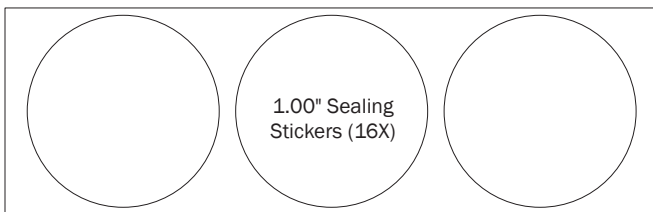

1.00" Sealing Stickers (16X)



Anti-Seize (1X)

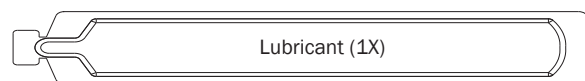

Lubricant (1X)

FBM-0062 ASSEMBLY SEQUENCE

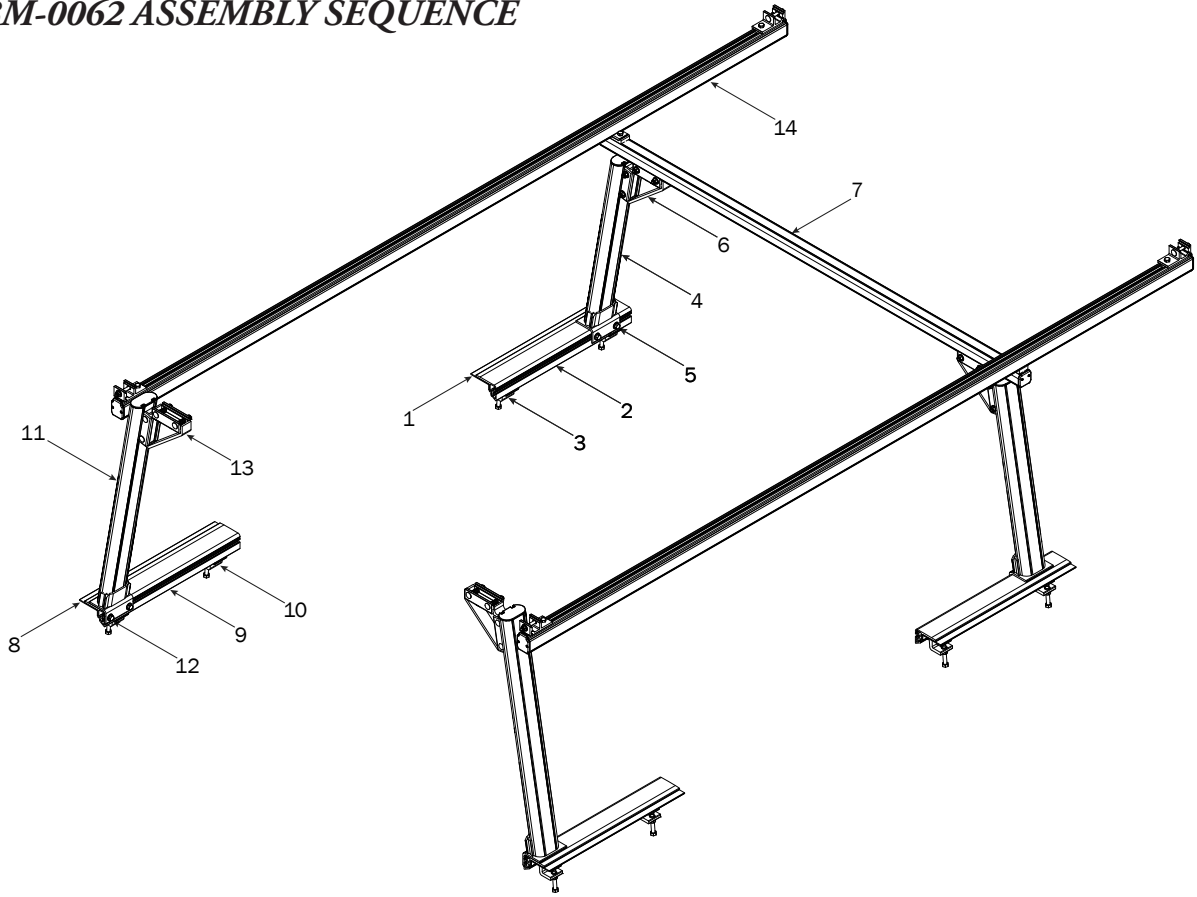

1 Place the PTR Foot Pad onto the truck's bed rail.

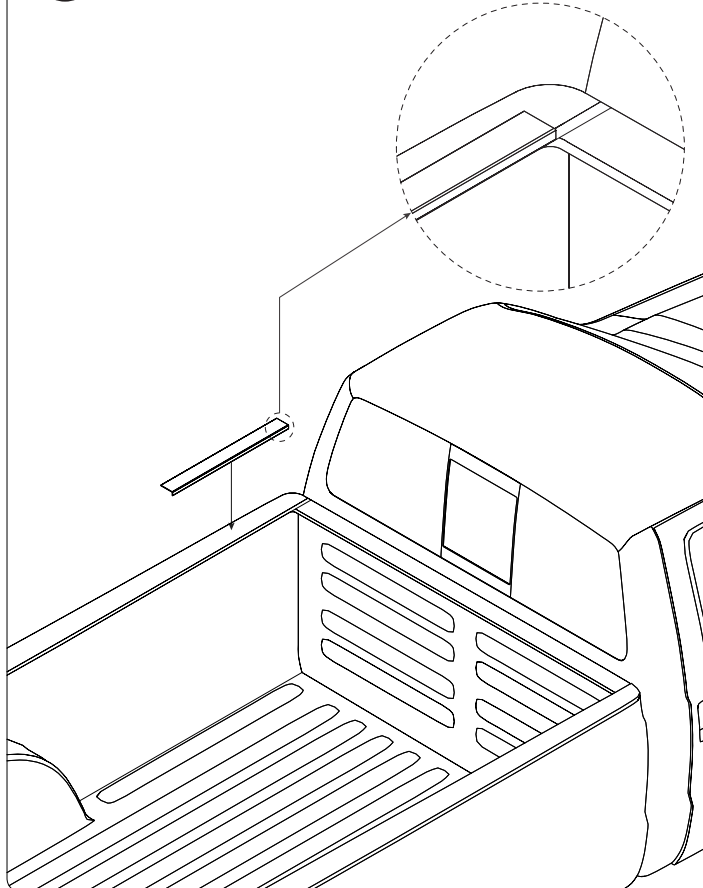

2 Place the PTR Tube Foot on top of the bed rail Foot Pad.

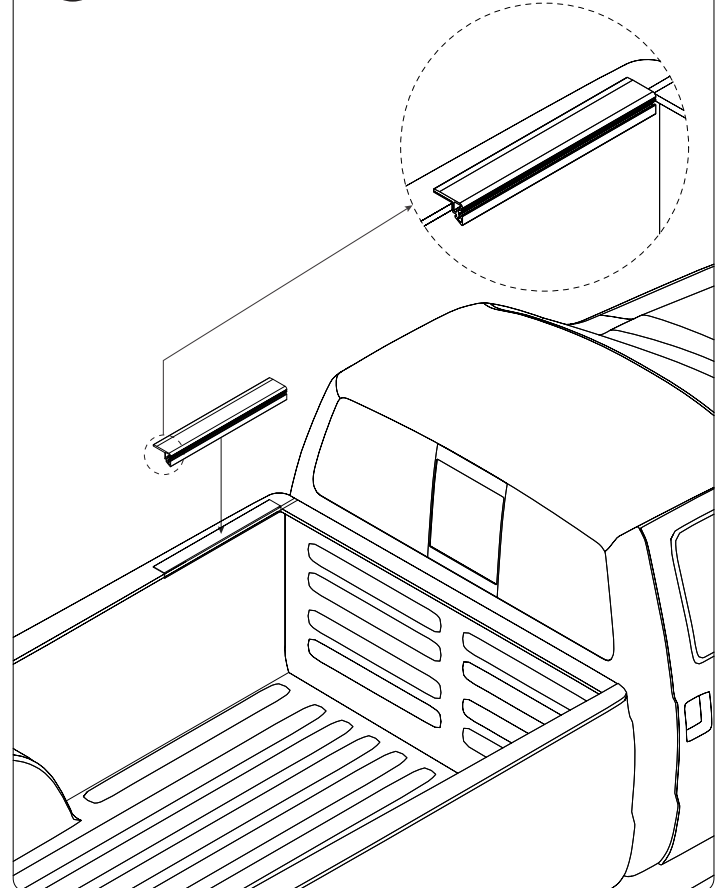

PBR-0021 RACK ASSEMBLY—FBM ASSEMBLY

PRIME DESIGN™
A Safe Fleet Brand

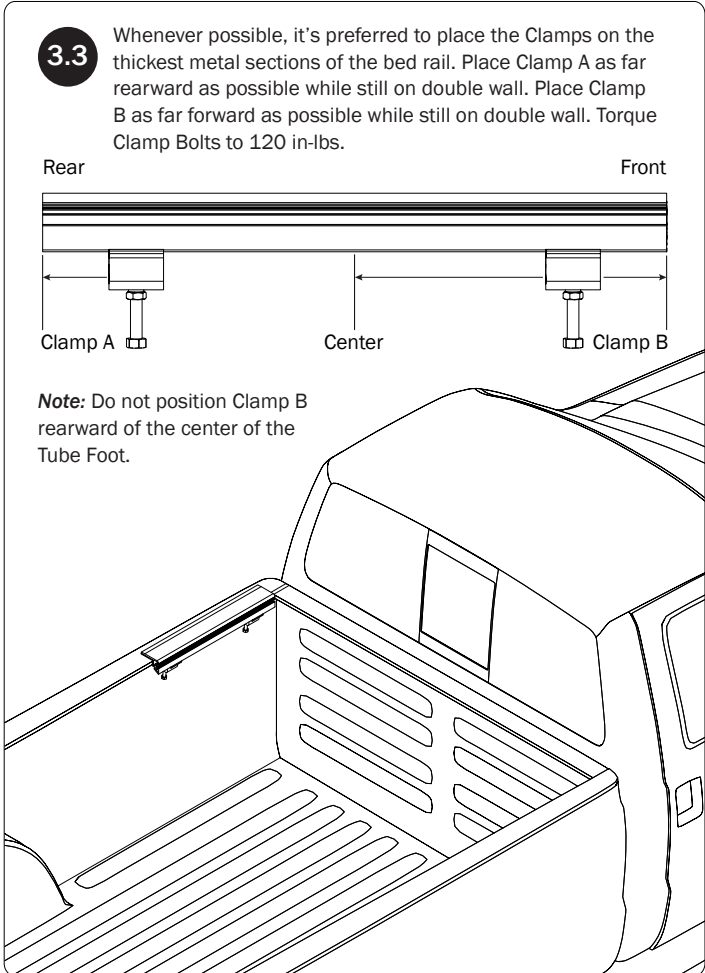
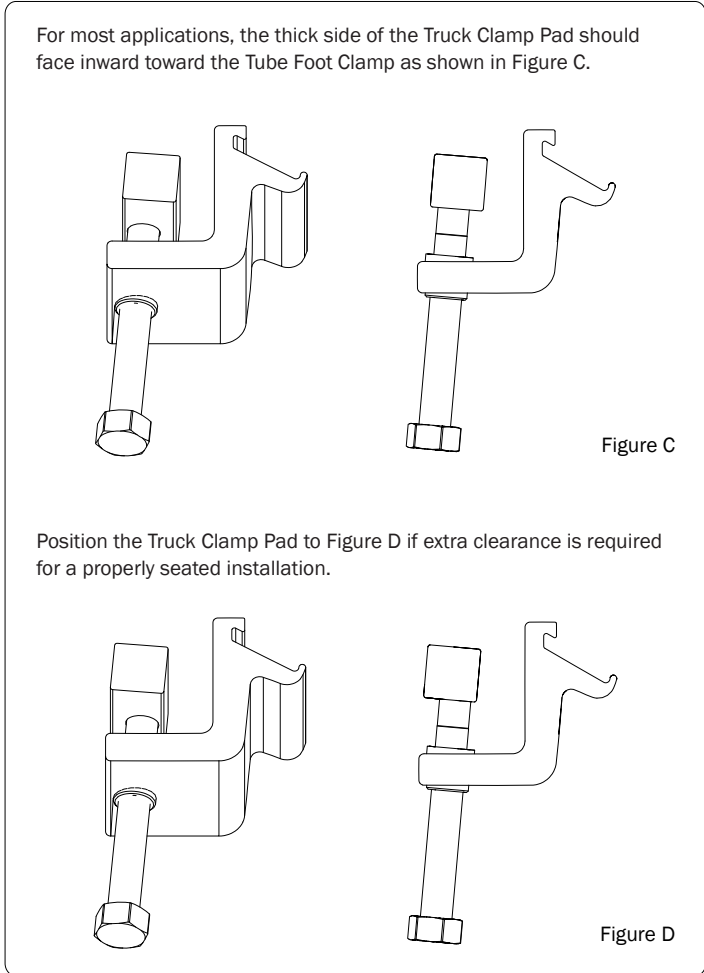
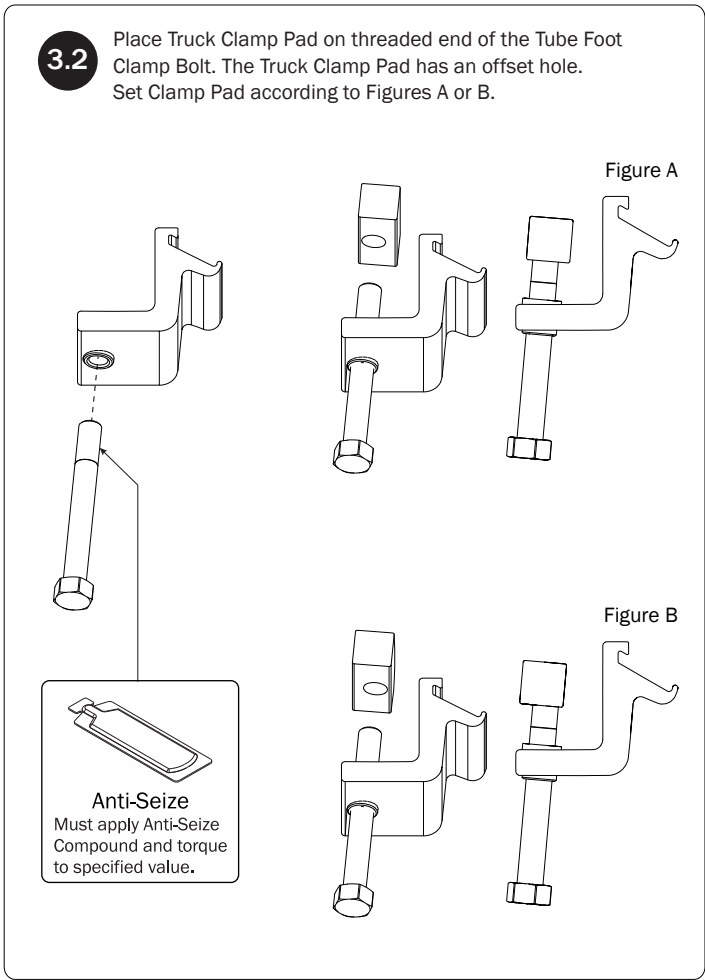
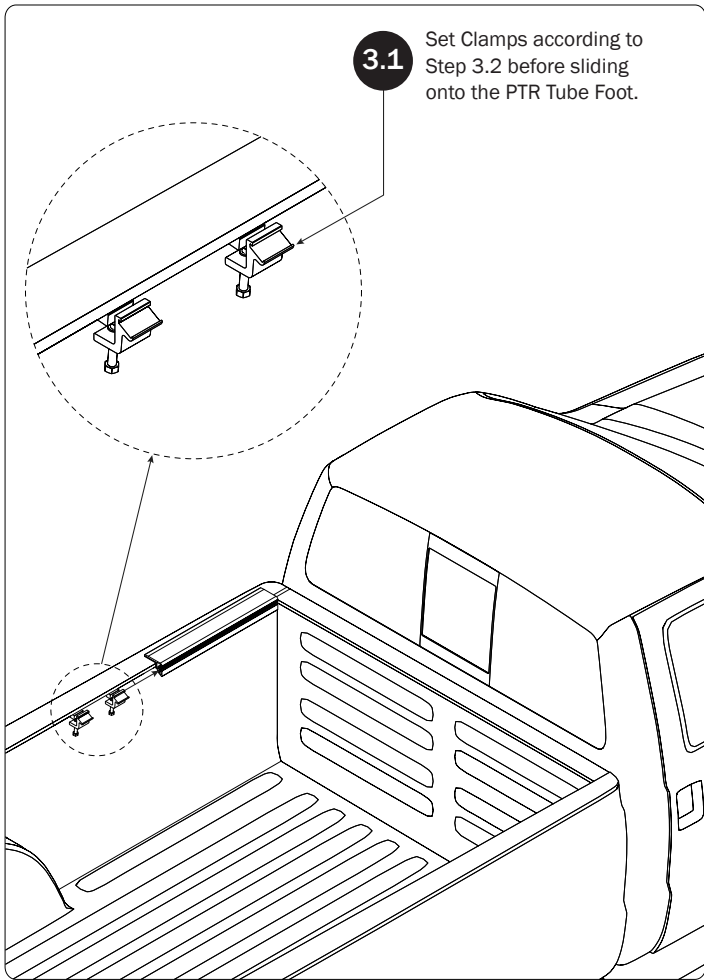

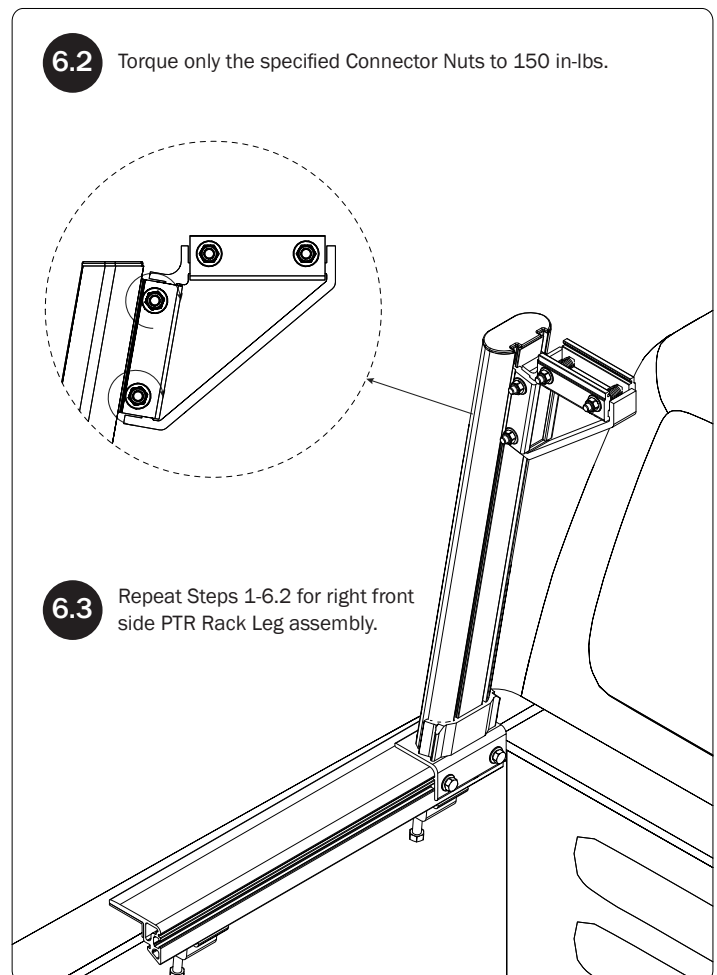
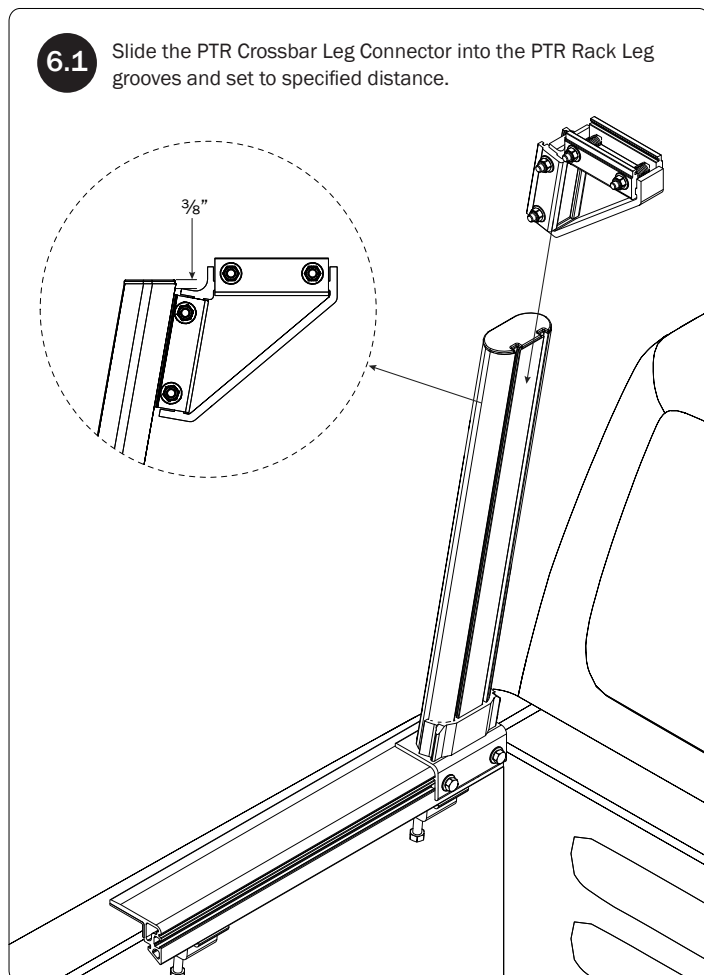
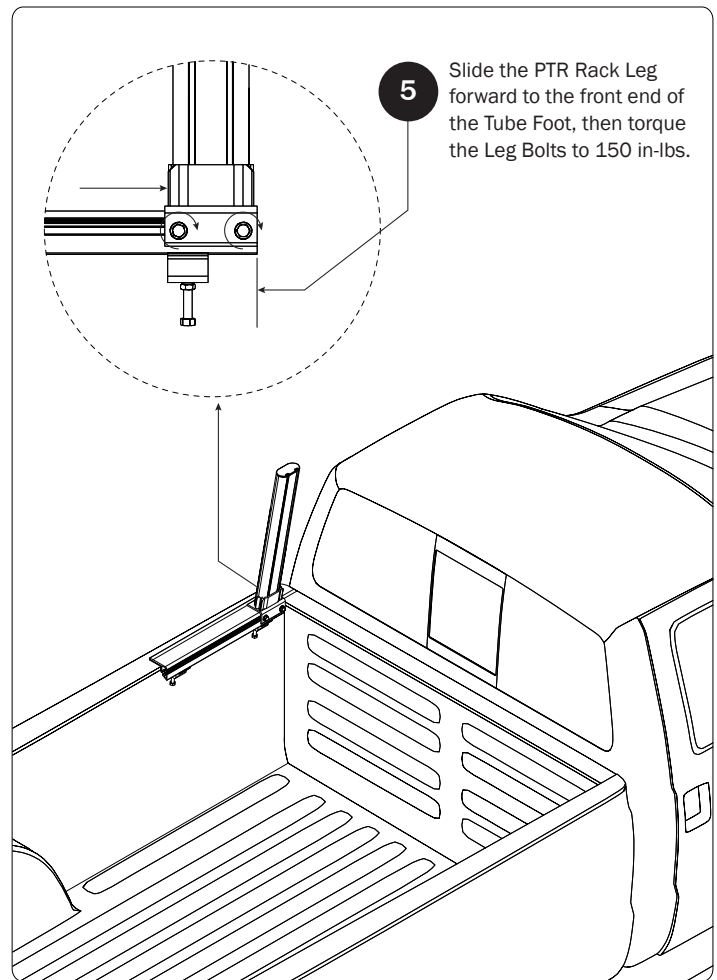
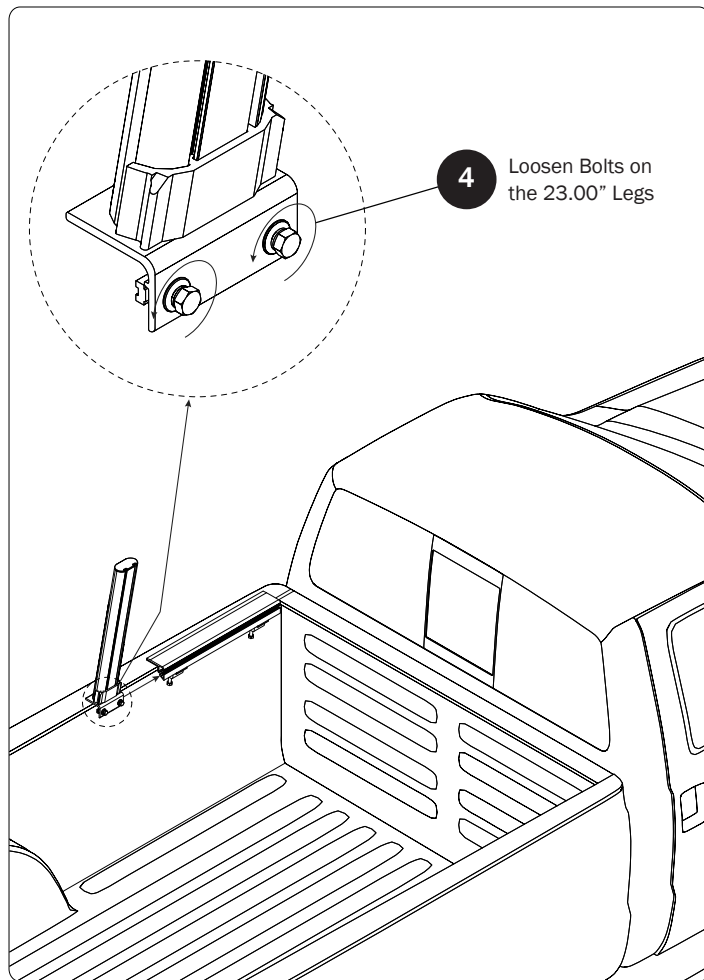

7.1 Place the Crossbar onto the PTR Rack Leg Connectors.

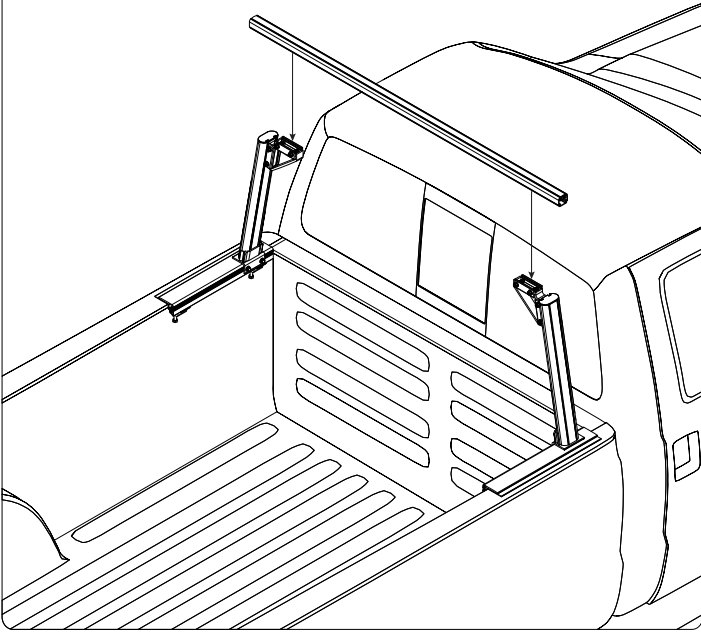

7.2 Center the Crossbar onto the PTR Rack Legs as shown.

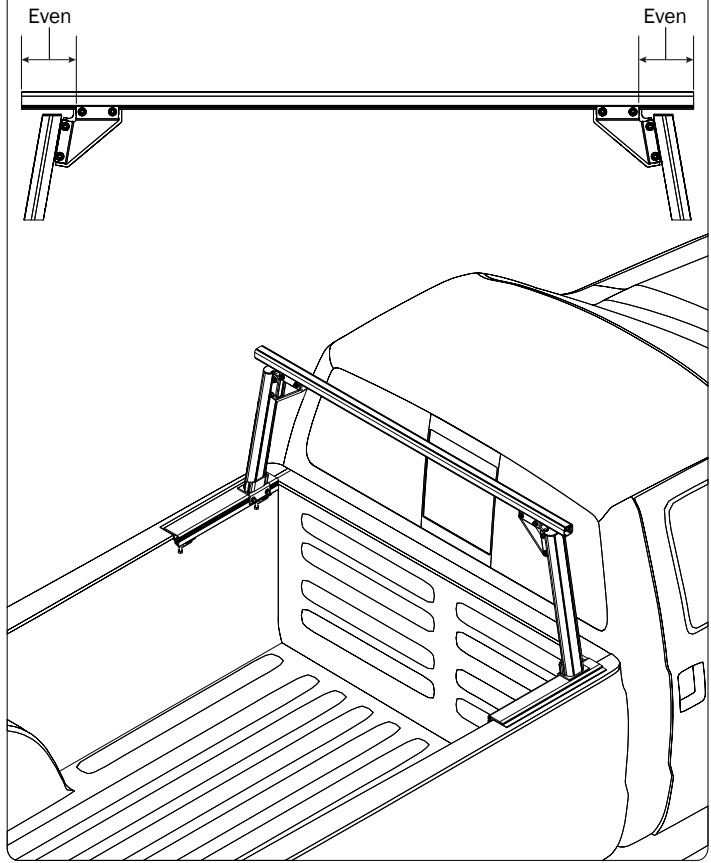

7.3 Torque nuts to 150 in-lbs.

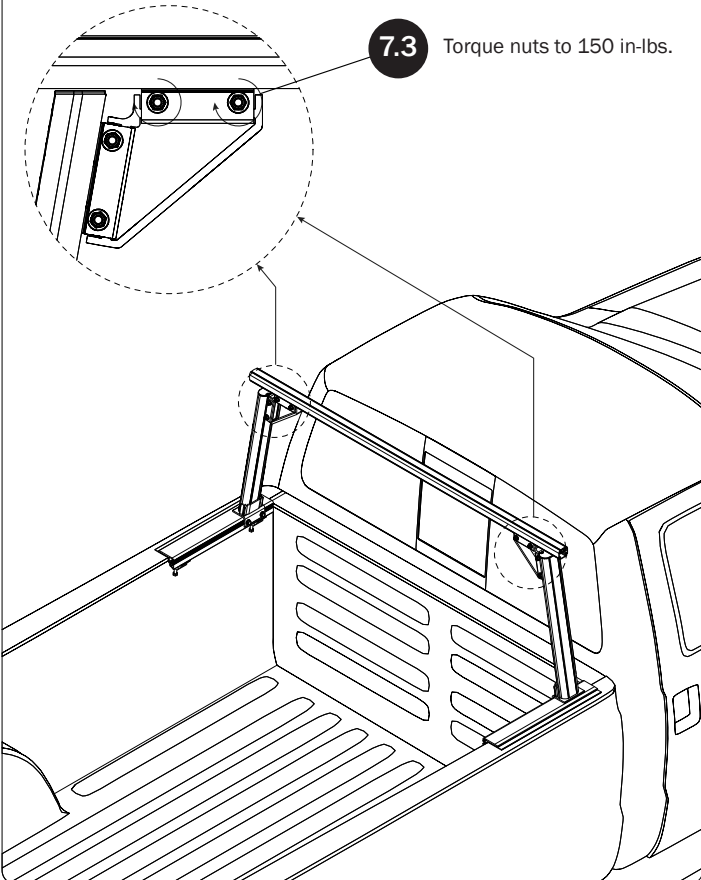

7.4 Position the Crossbar Brackets onto Crossbar and position as shown. Do not tighten Brackets until Step 16.6. Install the Crossbar End Caps using the supplied screws.

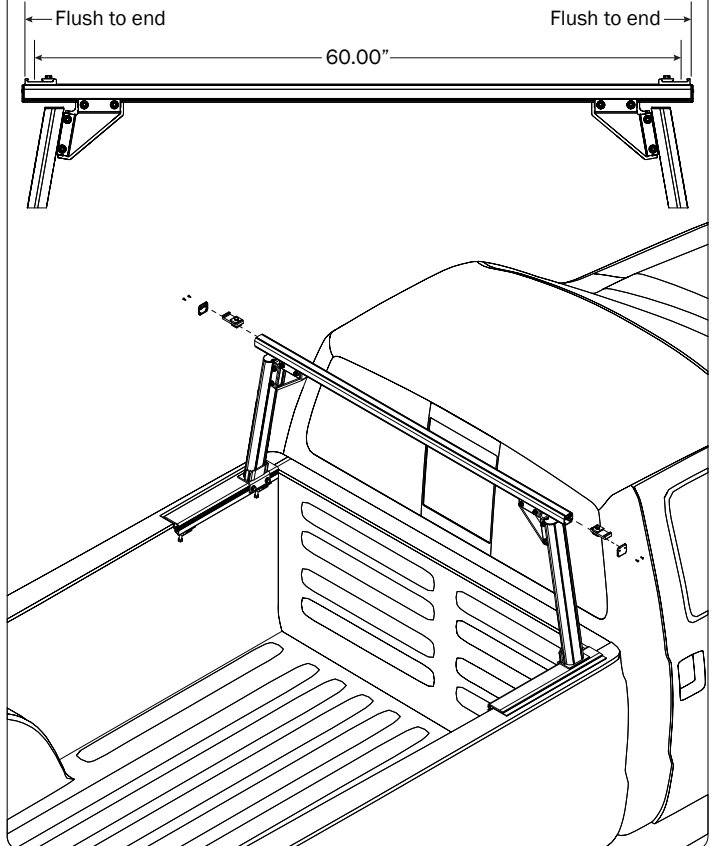

8 Place the Foot Pad onto the truck's bed rail.

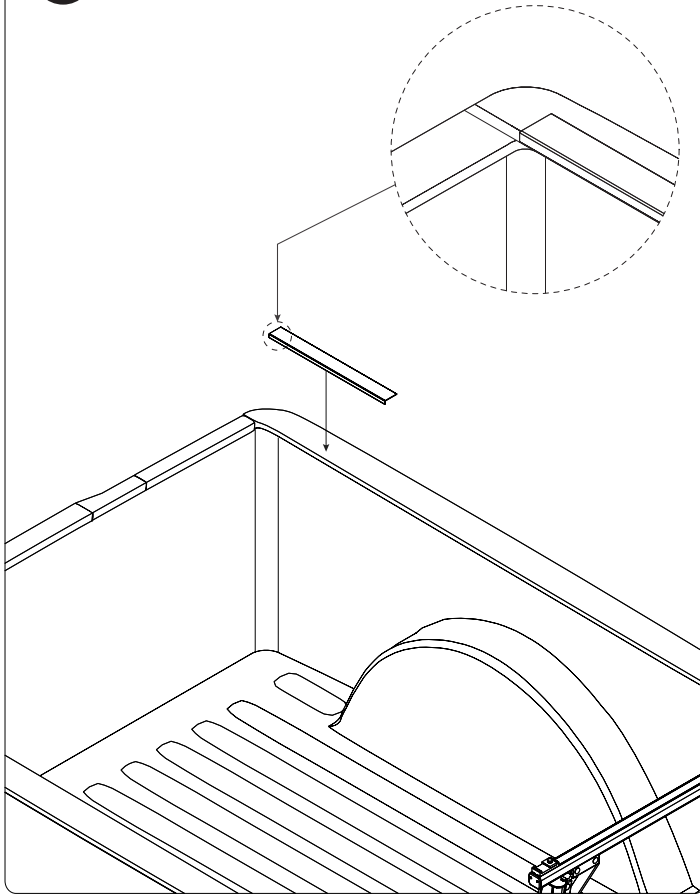

9 Place the PTR Tube Foot on top of the bed rail Foot Pad.

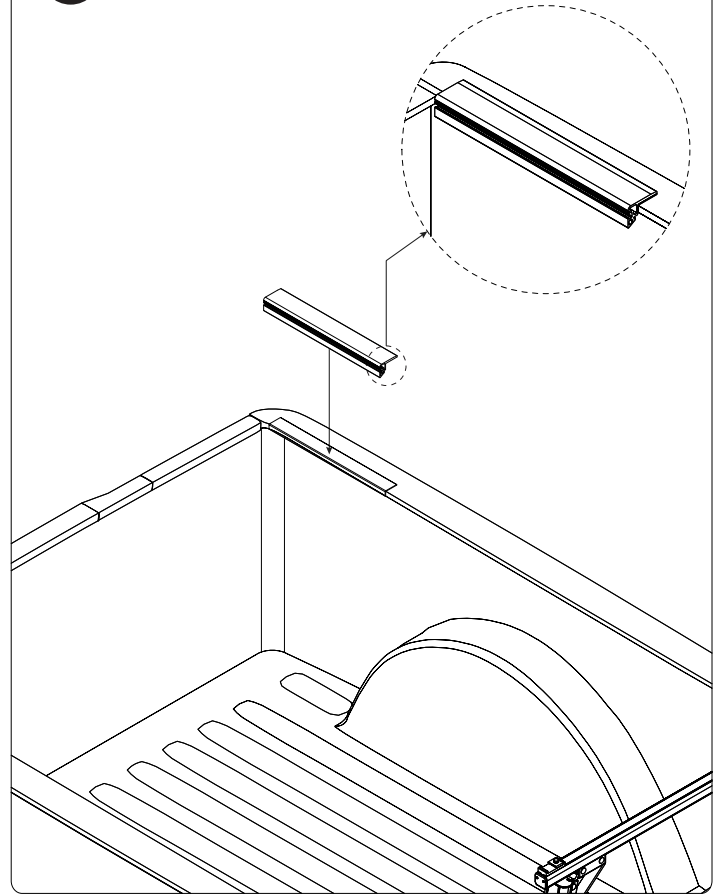

10.1

Set Clamps according to Step 10.2 before sliding onto PTR Tube Foot.

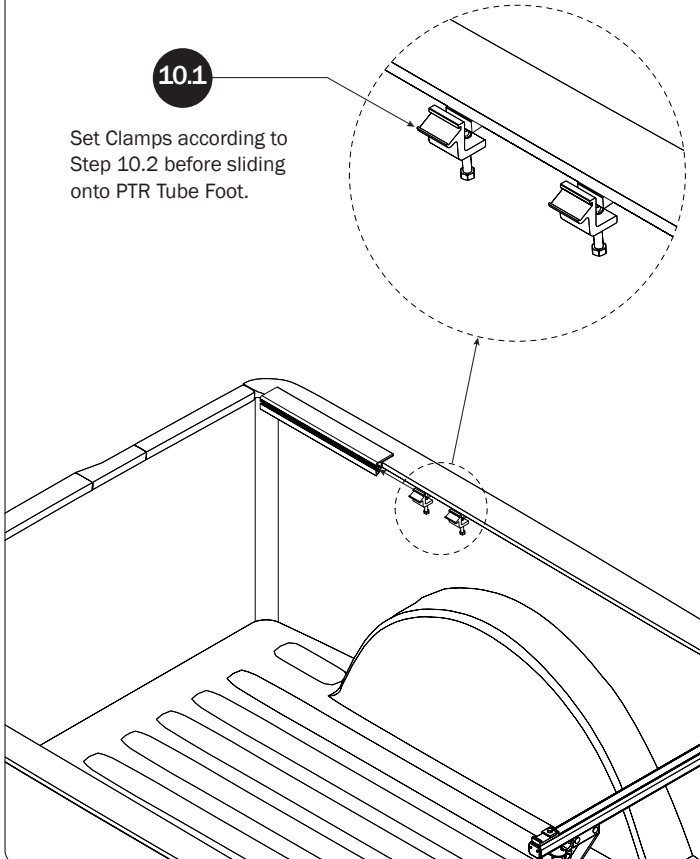

10.2

Place Truck Clamp Pad on threaded end of the Tube Foot Clamp Bolt. The Truck Clamp Pad has an offset hole. Set Clamp Pad according to Figures E or F.

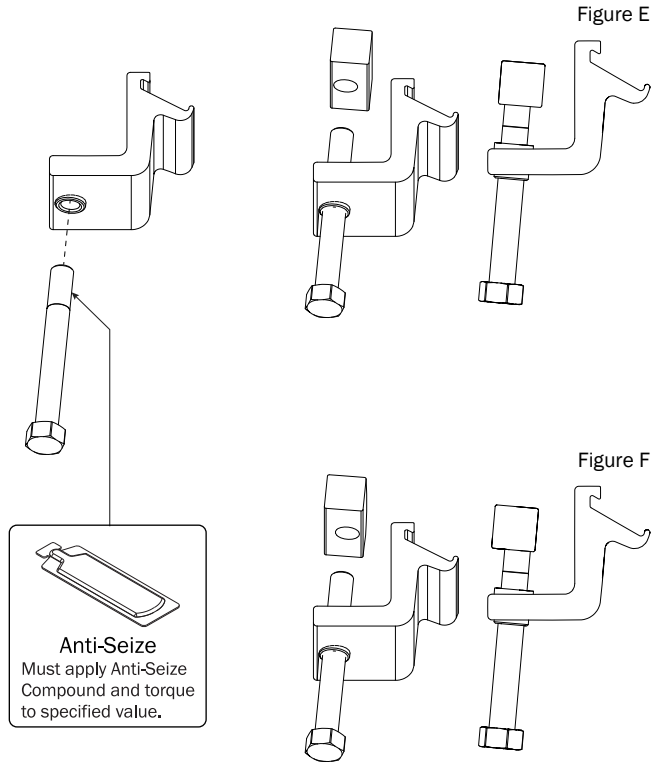

For most applications, the thick side of the Truck Clamp Pad should face inward toward the Tube Foot Clamp as shown in Figure E.

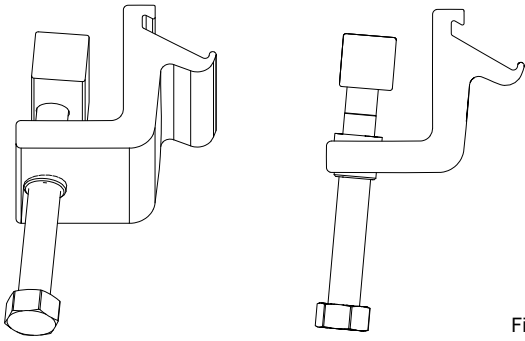

Figure E

Position the Truck Clamp Pad to Figure F if extra clearance is required for a properly seated installation.

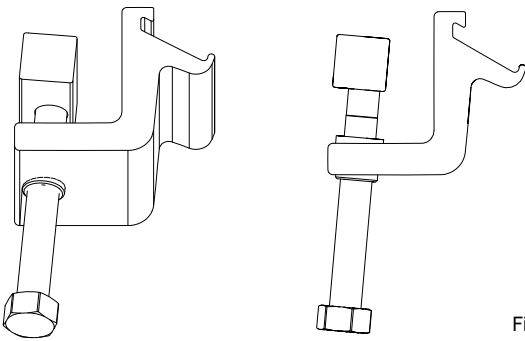
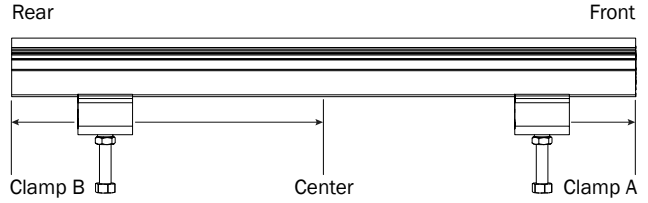
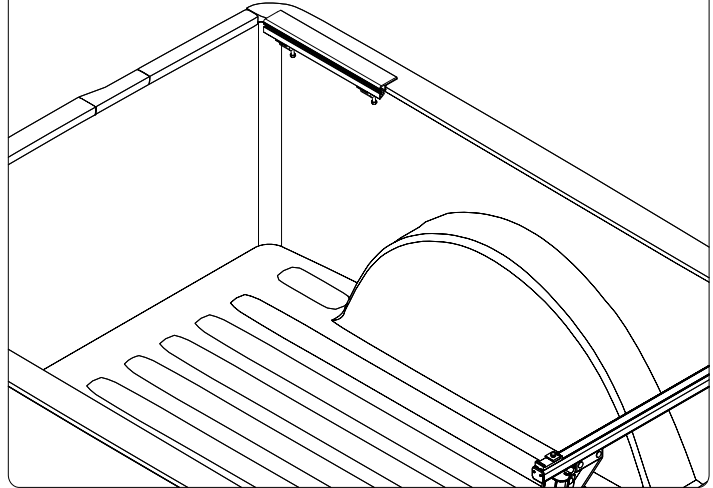

Figure F

10.3 Whenever possible, it's preferred to place the Clamps on the thickest metal sections of the bed rail. Place Clamp A as far forward as possible while still on double wall. Place Clamp B as far rearward as possible while still on double wall. Torque Clamp Bolts to 120 in-lbs.



Note: Do not position Clamp B rearward of the center of the Mounting Foot.



11

Loosen Bolts on the 28.50" Legs

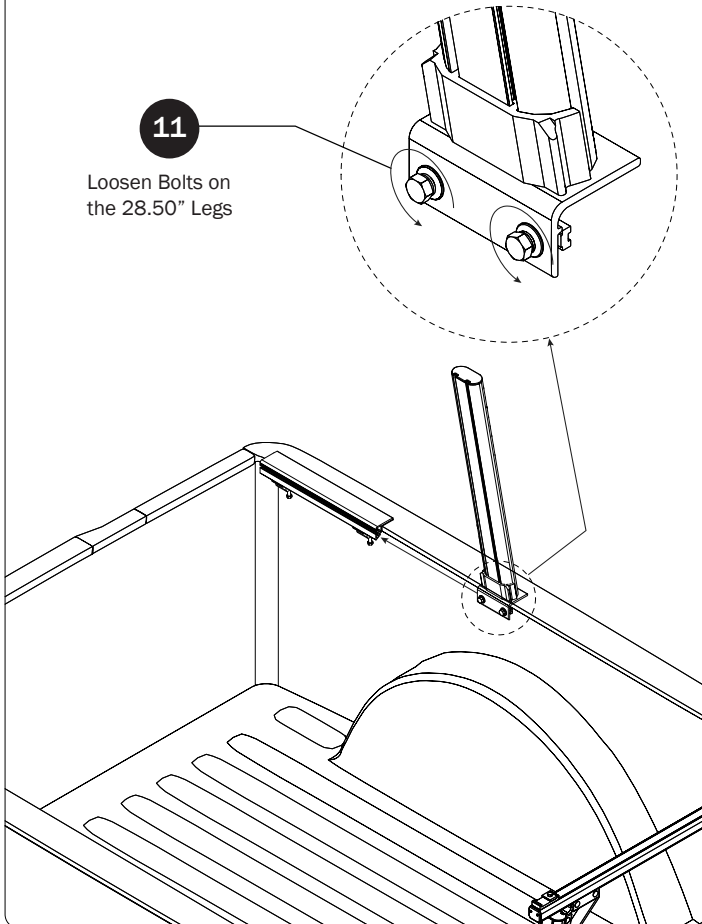

12

Slide the PTR Rack Leg rearward to the back end of the Tube Foot, then torque the Rack Leg Bolts to 150 in-lbs.

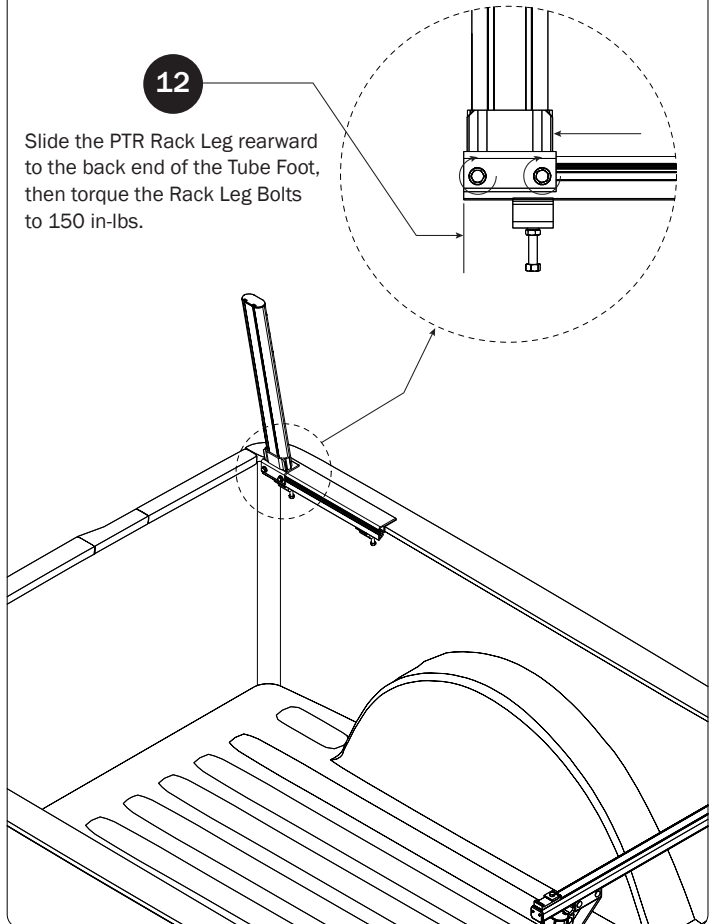

13.1 Slide the PTR Crossbar Leg Connector into the PTR Rack Leg grooves and set to specified distance.

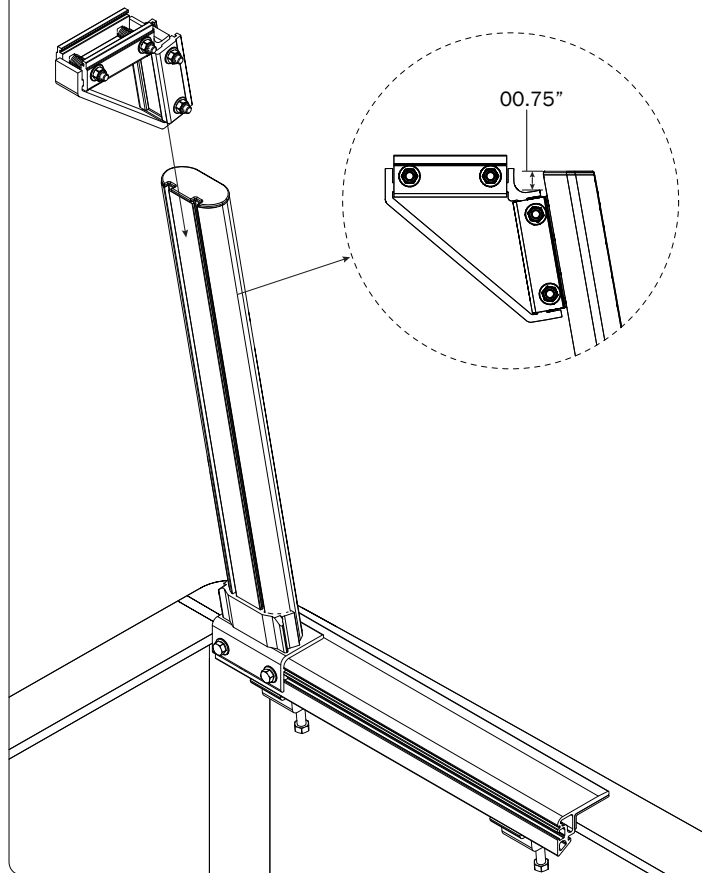

13.2 Torque only the specified Connector nuts to 150 in-lbs.

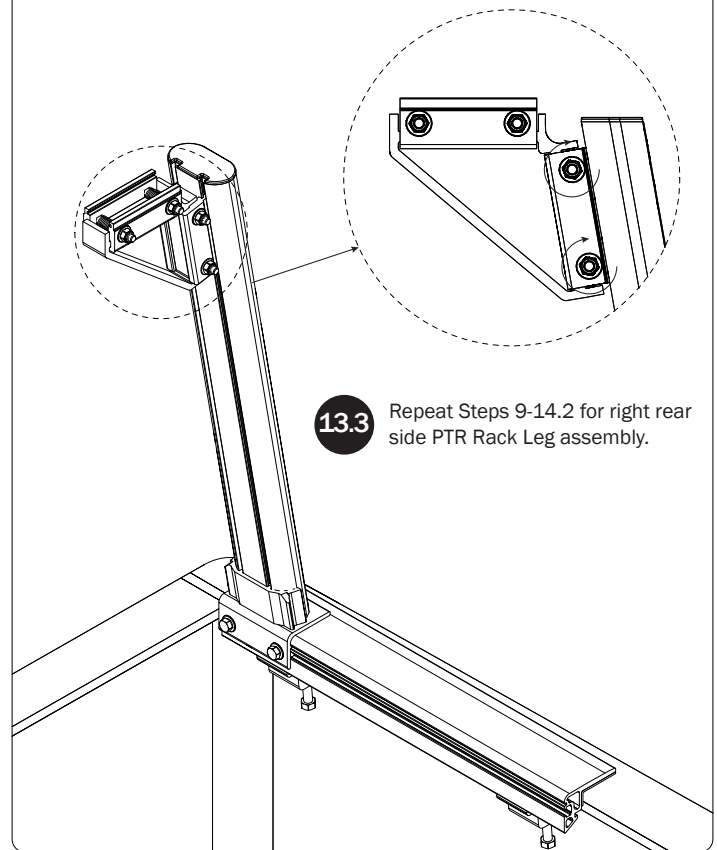

13.3 Repeat Steps 9-14.2 for right rear side PTR Rack Leg assembly.

14.1 Loosen the 30MM Hex Head Bolt to allow the Aluminum Strip Nut into the Suspension Bar's upper groove. Loosen the clamp nuts for Crossbar installation on Steps 15.1 and 17.1.

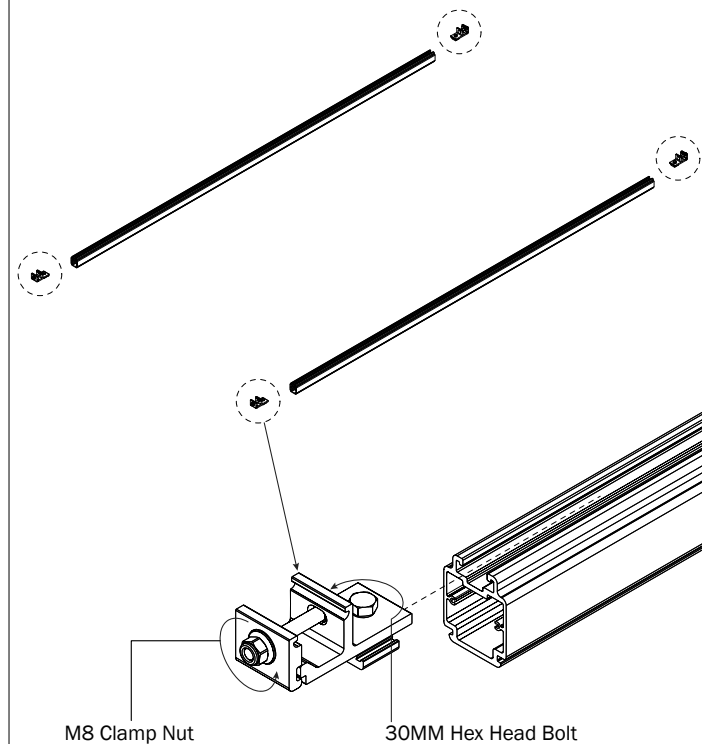

14.2 Attach the Suspension Bar End Caps using supplied screws.

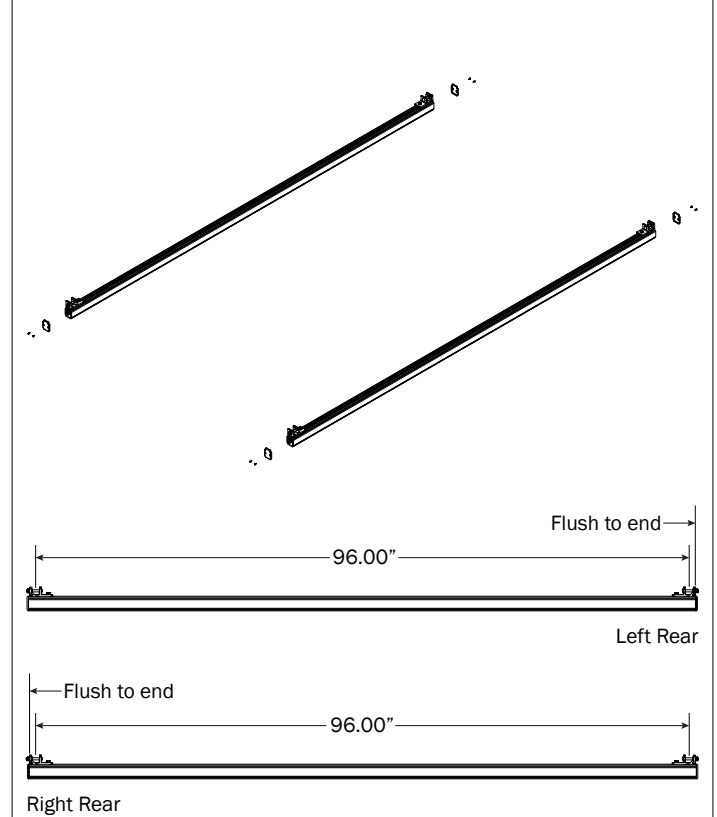

**RIGHT ROTATION
ASSEMBLY SEQUENCE**

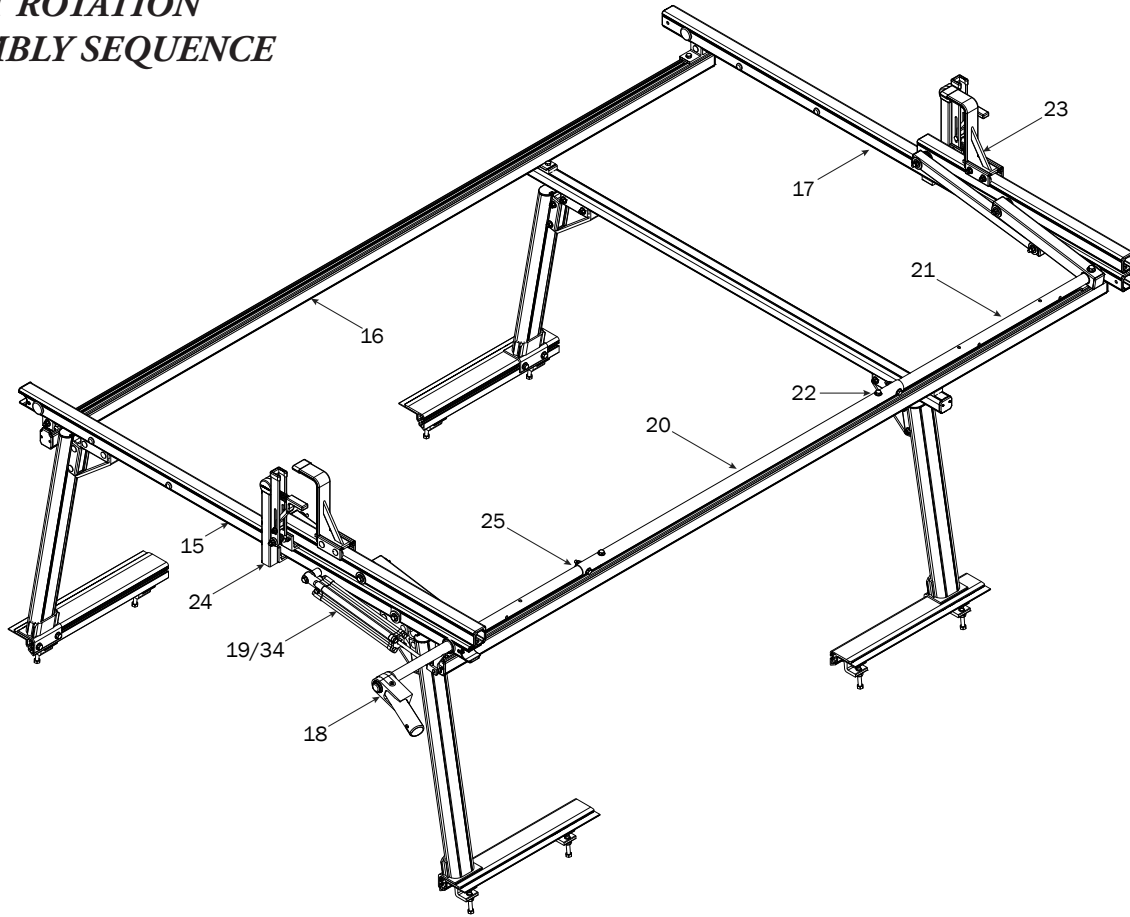

REAR CROSSBAR

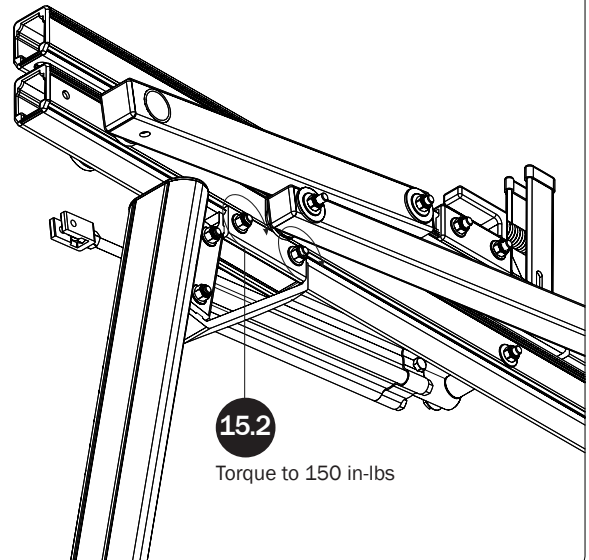
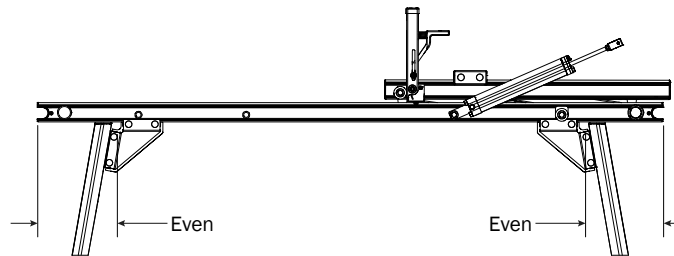
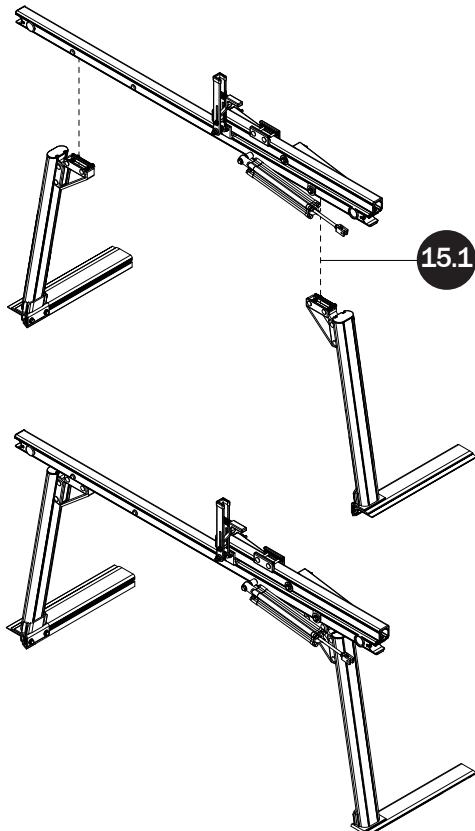

SUSPENSION BARS

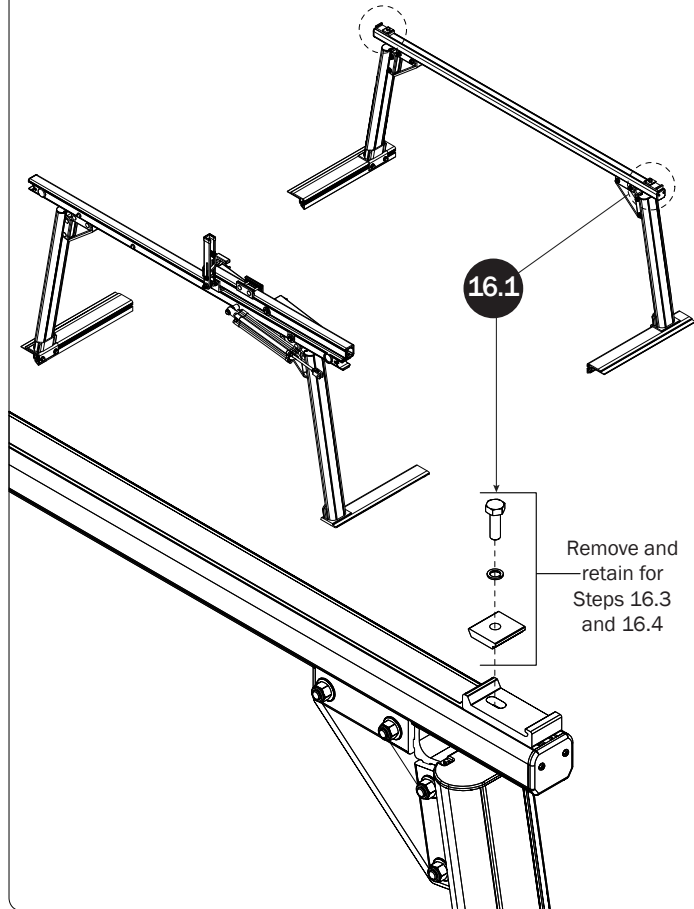

16.2

Place the Suspension Bars on the Front Crossbar Clamps as shown in Figure H, then attach the rear Suspension Bar Clamps to the bottom of the Rear Crossbar as shown in Figure G.

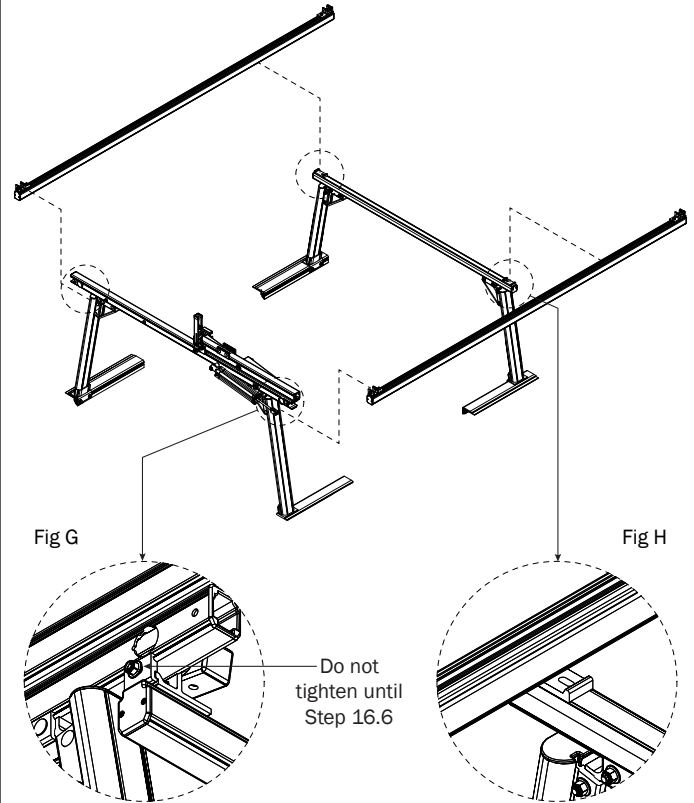

16.3

Slide the Bracket Clamp into the Crossbar groove and slide onto the Crossbar Mounting Bracket aligning the bolt holes.

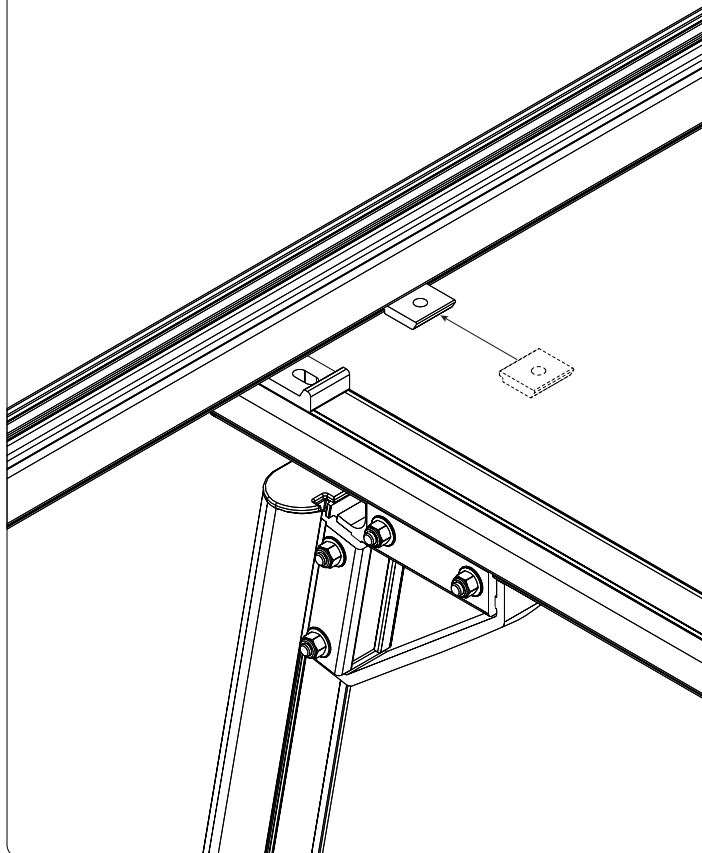

16.4

Install the Crossbar Mounting Bracket hardware, but do not tighten until Step 16.6.

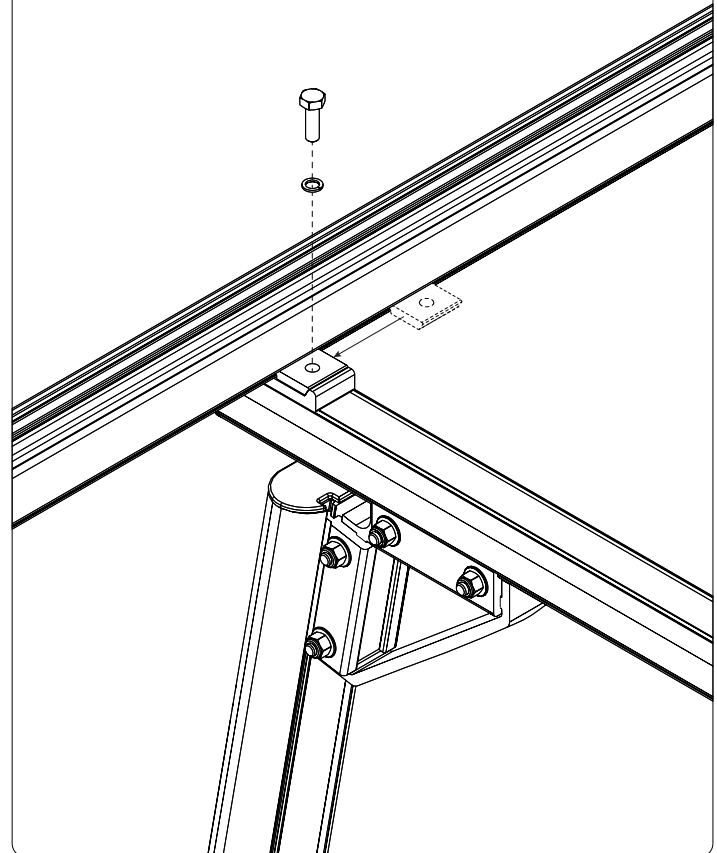

16.5 Adjust Suspension Bar according to Figure I

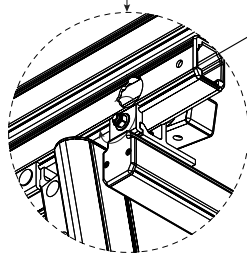
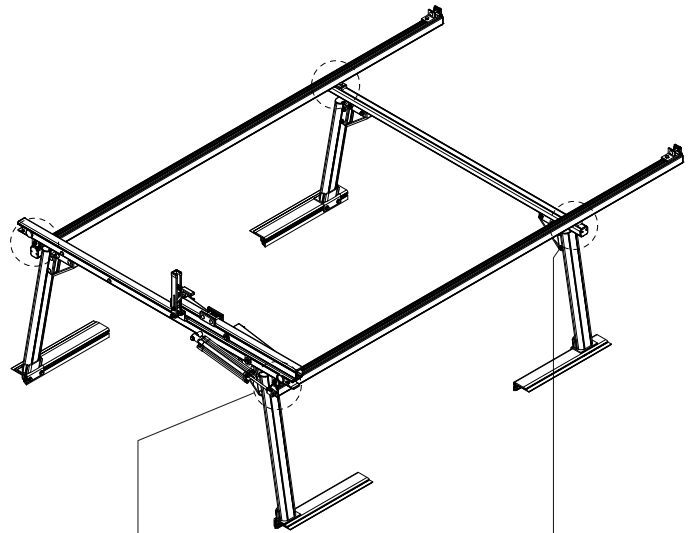
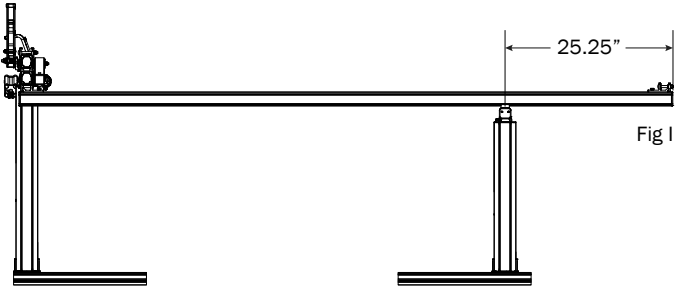
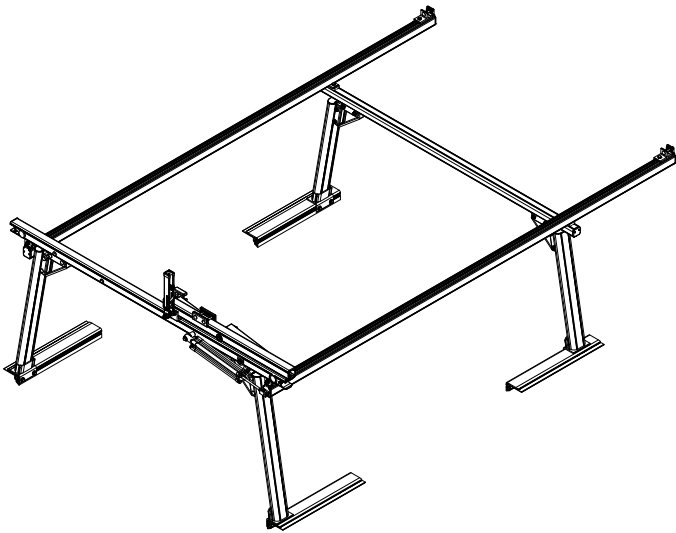

16.6

Torque to 120 in-lbs

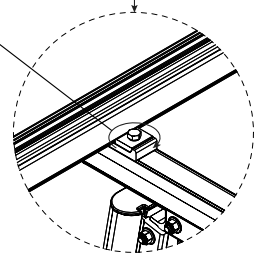

FRONT CROSSBAR

17.1



17.2

Adjust Front Crossbar on Suspension Channels as shown.

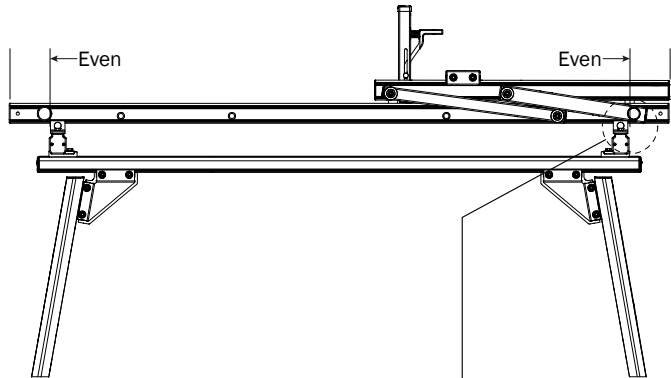

17.3

Torque to 120 in-lbs

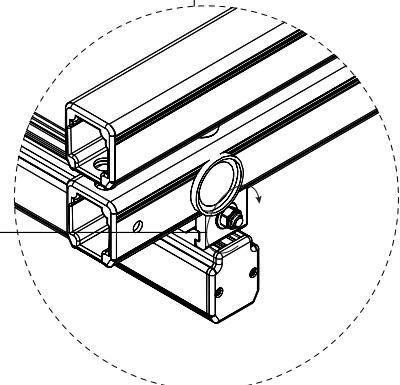

REAR DRIVE SHAFT

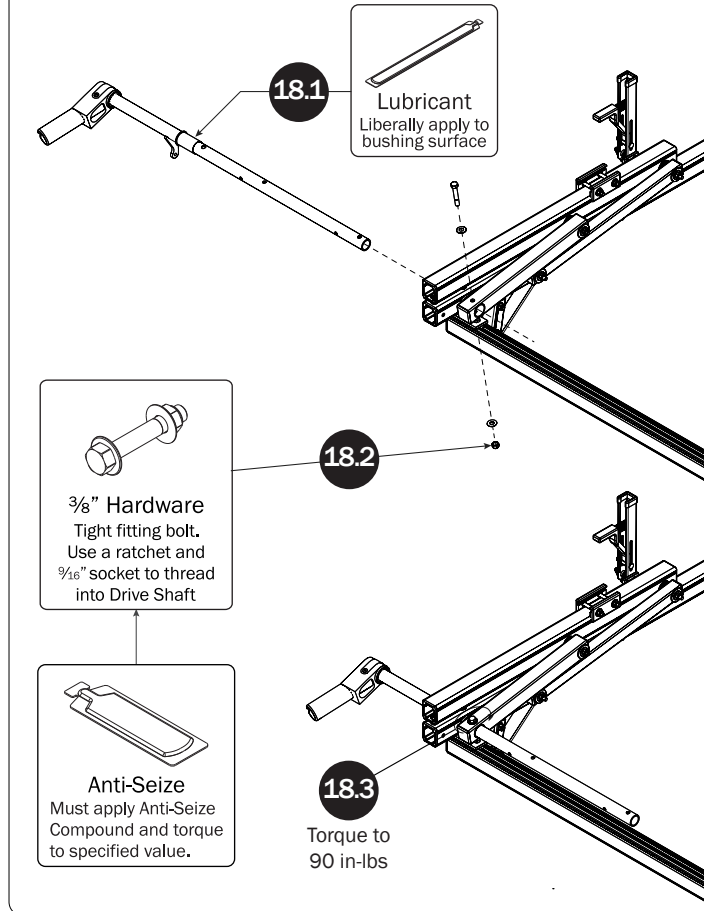

CYLINDER HARDWARE

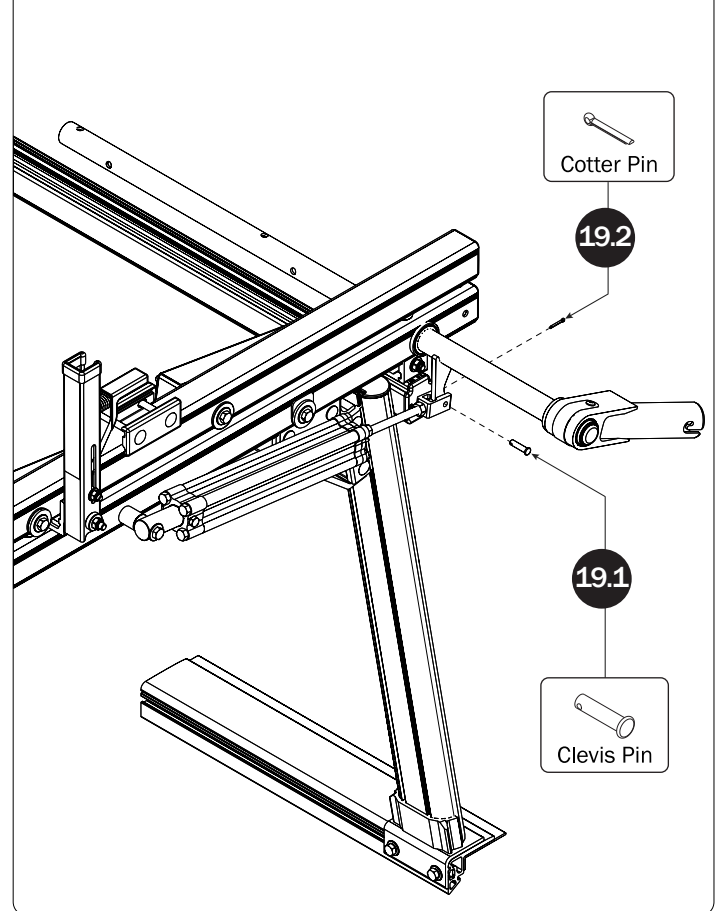

CONNECTING BAR

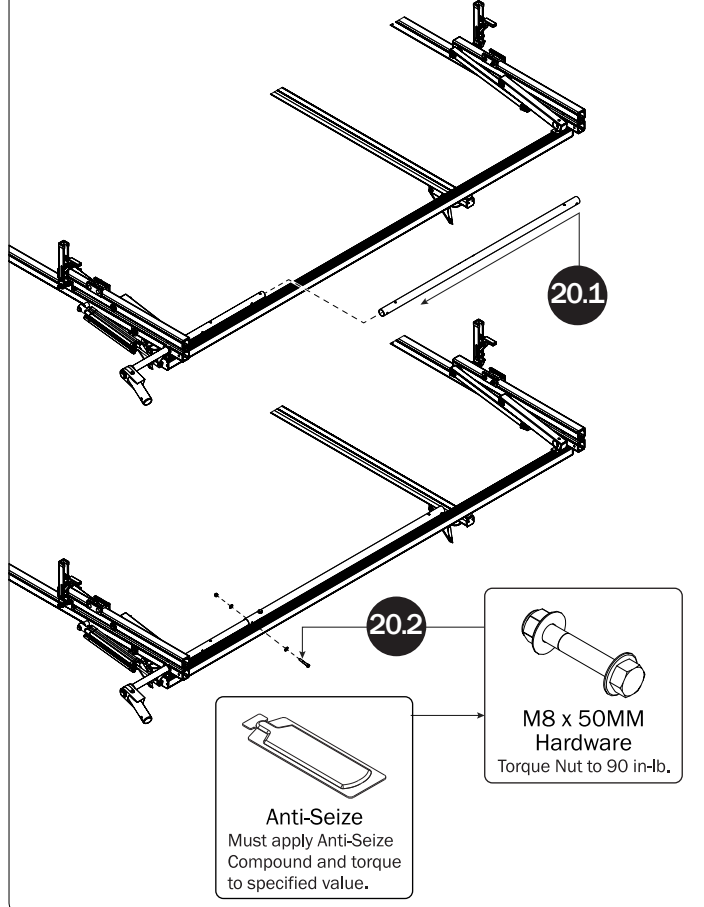

FRONT DRIVE SHAFT

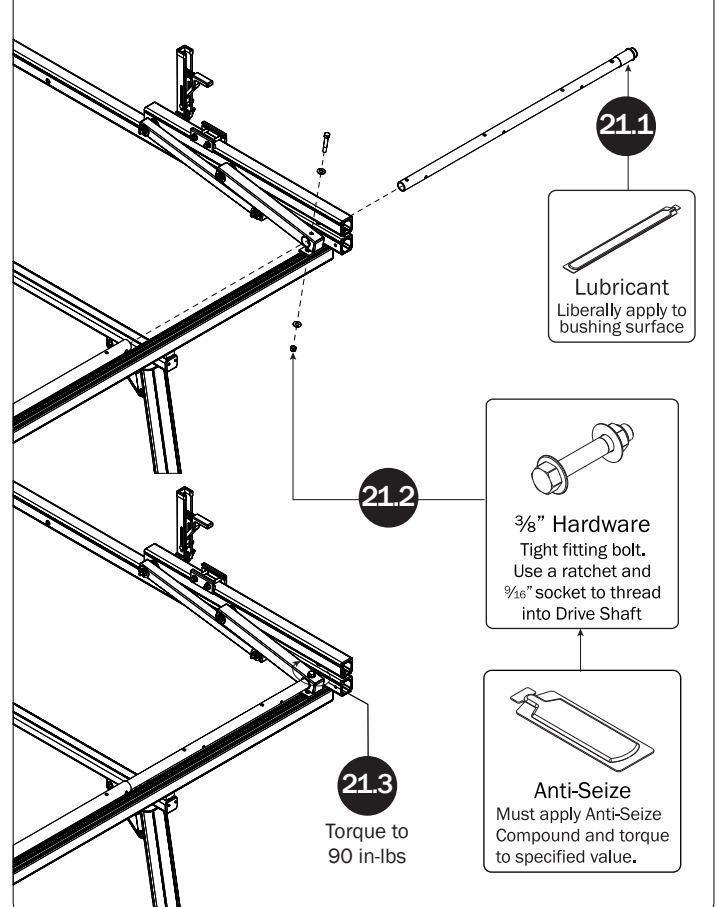

CONNECTING BAR FASTENERS

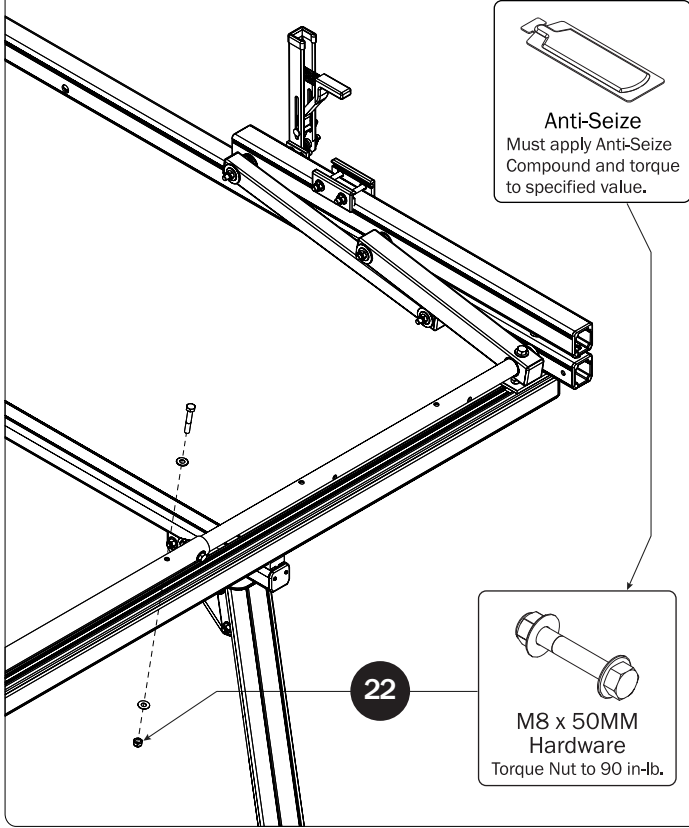

Z POSTS

SEE QUICK START GUIDE FOR ADJUSTMENTS

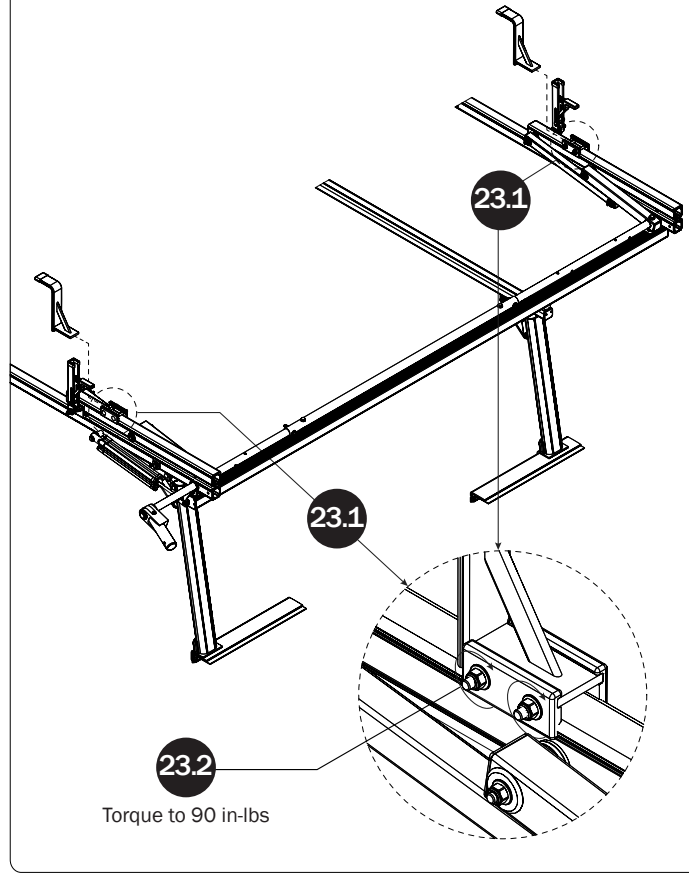

L POSTS

SEE QUICK START GUIDE FOR ADJUSTMENTS

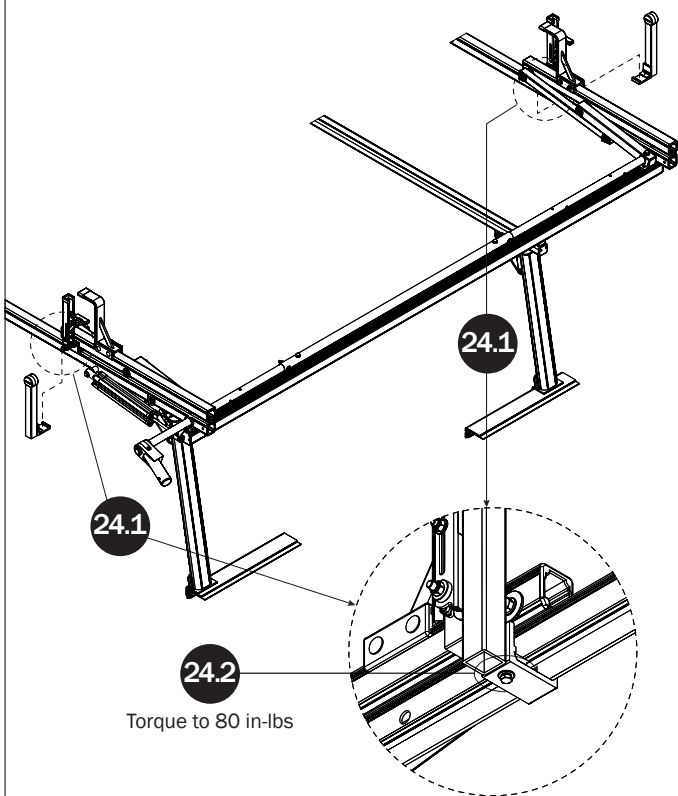

DRIVE SHAFT SEALING

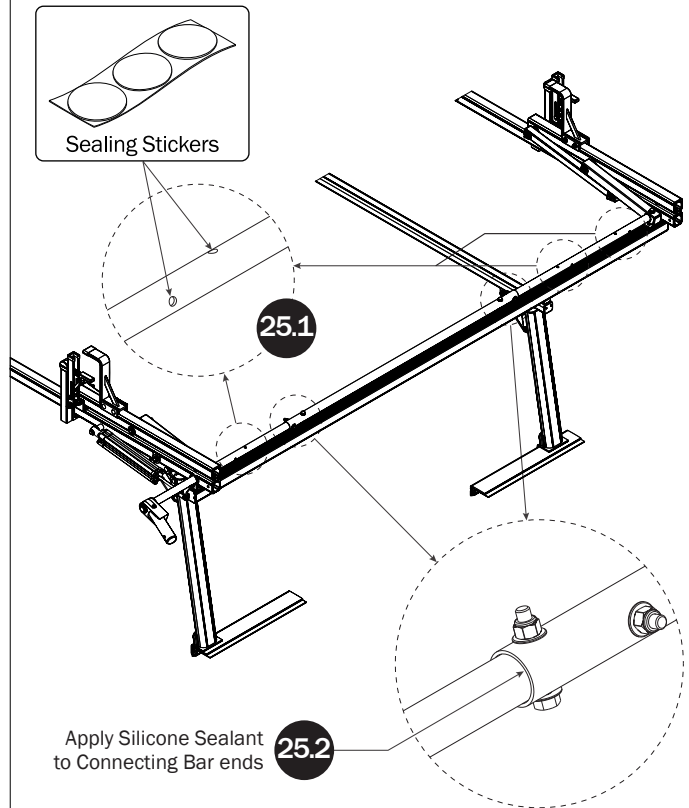

LEFT BASE ASSEMBLY SEQUENCE

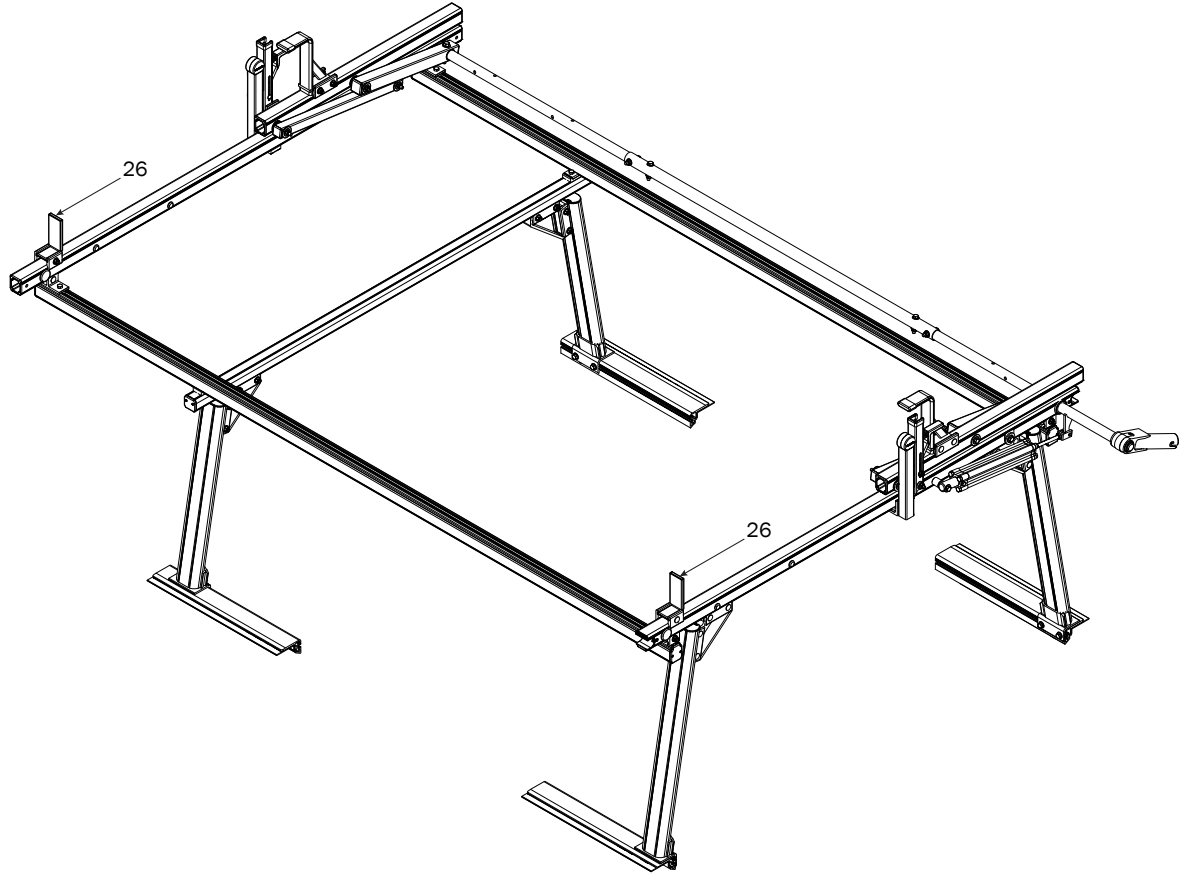

LADDER STOPS

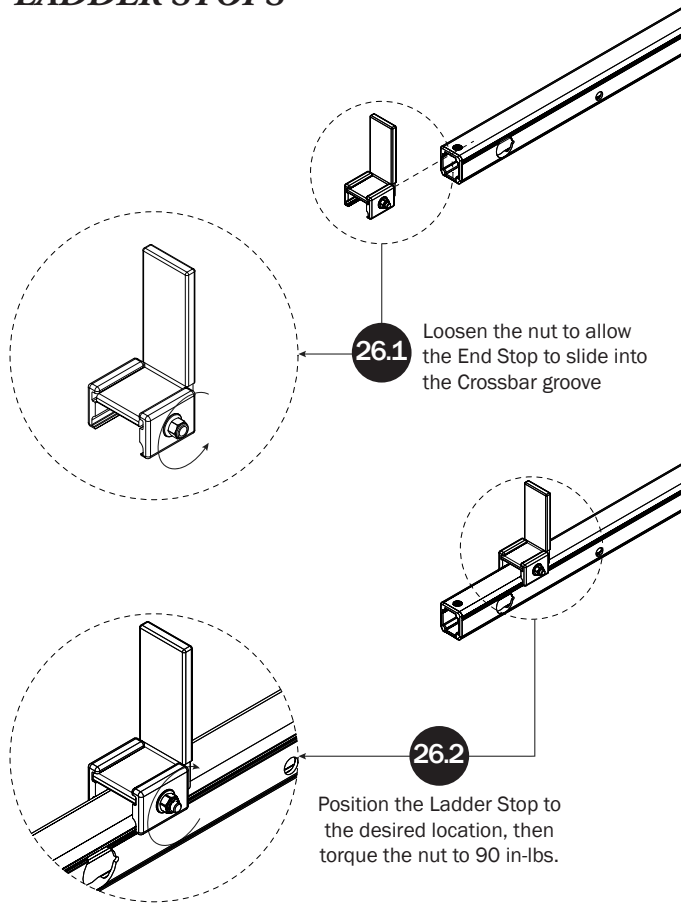

CYLINDER ADJUSTMENT

Adjust the Cylinder Flow Control Screw to allow approximately 3 seconds time for the ladder to glide down when operating the loaded Ladder Rack.

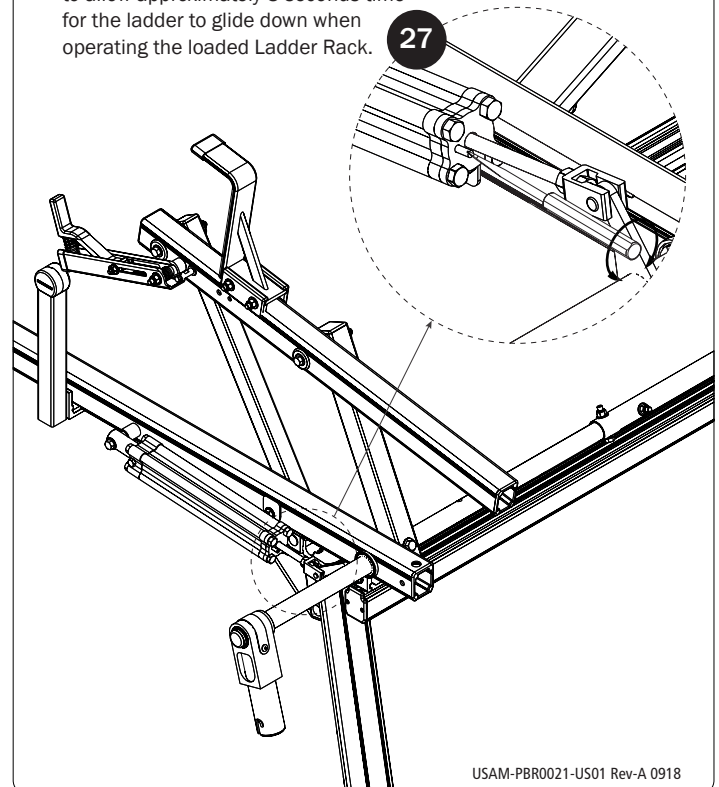

USAM-PBR0021-US01 Rev-A 0918