

PRIME DESIGN™

A Safe Fleet Brand

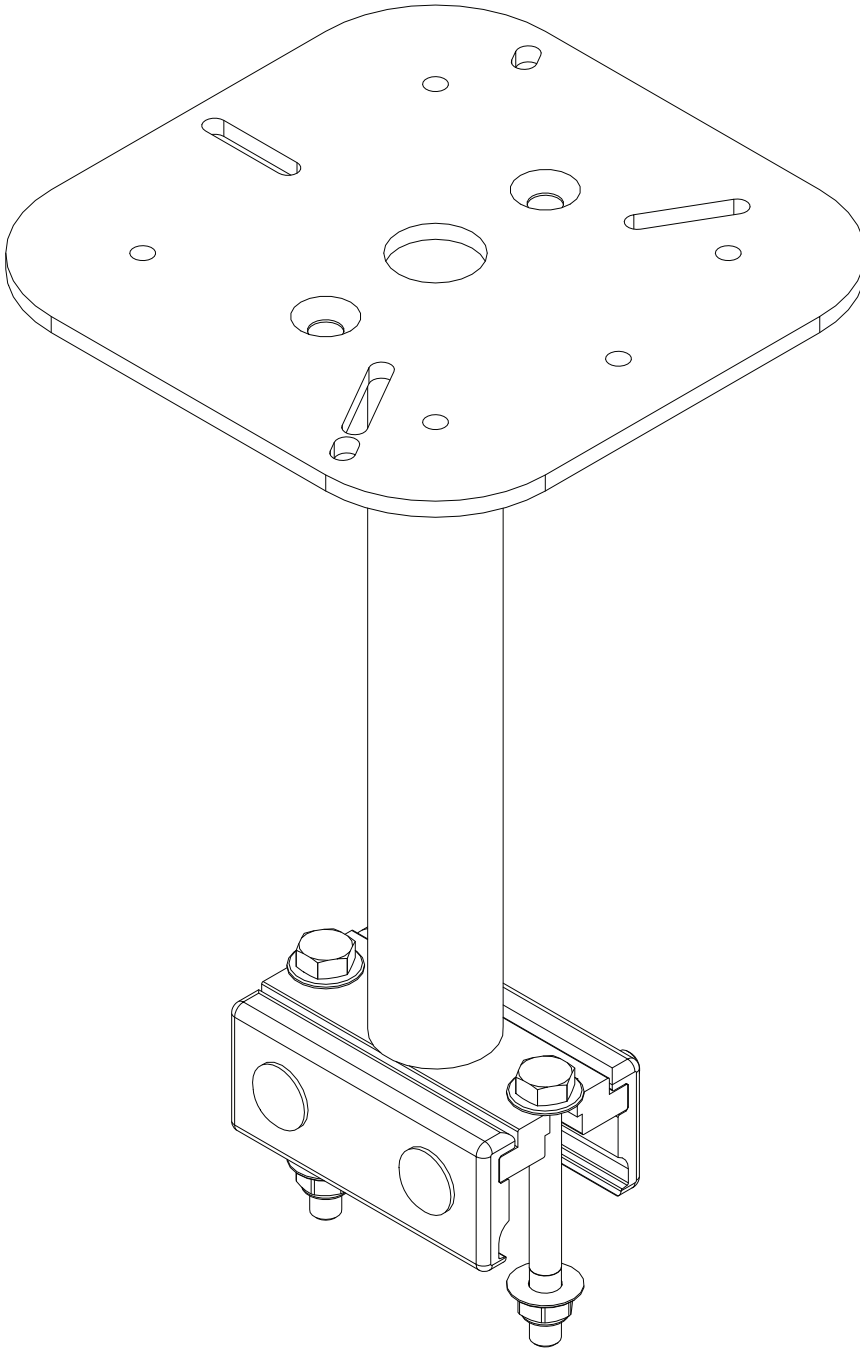

G1-G4 ACCESSORY LIGHT HOLDER KIT, 9.00"

PRIME DESIGN, A SAFE FLEET BRAND

Address: 580 Opperman Drive, Eagan, MN 55123 • Toll Free: 1.8.PRIME.RACK

Fax: 651-552-1799 • Email: info@primedesign.net • Website: www.primedesign.net

ASH 8125

CONTENTS OVERVIEW



Note: This Gen1-Gen4 Light Holder Kit is a direct replacement or retrofit for all Prime Design ErgoRack models. This kit includes all new hardware, and discards all used or removed hardware. For retrofitting on Gen1 Crossbars, it may be necessary to mark and drill holes into the Crossbar.

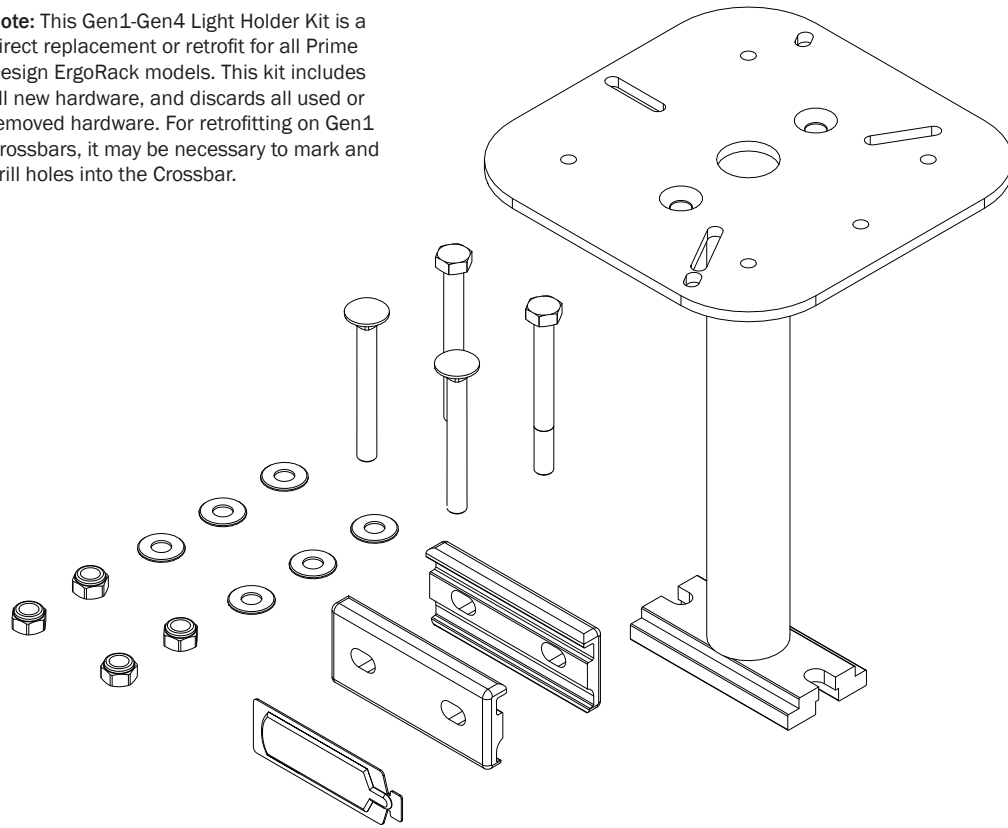

ASH-8125 Light Holder Kit

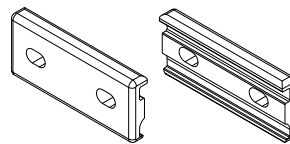
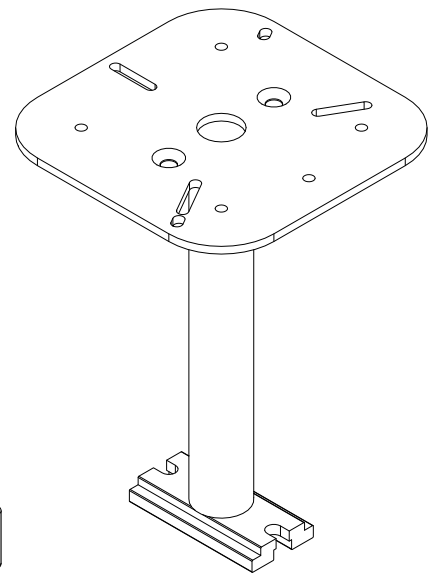

Light Holder Clamps (2X)

Light Holder (1X)

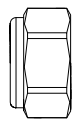

M8 Lock Nut (4X)

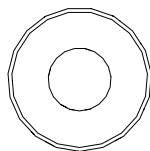

5/16" Flat Washer (6X)

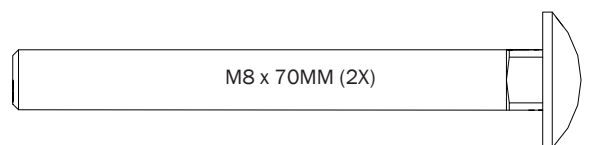

M8 x 70MM (2X)

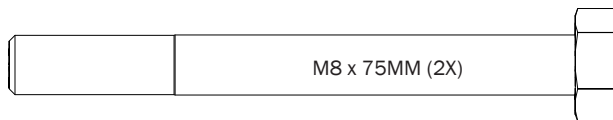

M8 x 75MM (2X)



Anti-Seize (1X)

GEN2-GEN4 LIGHT HOLDER REPLACEMENT SEQUENCE

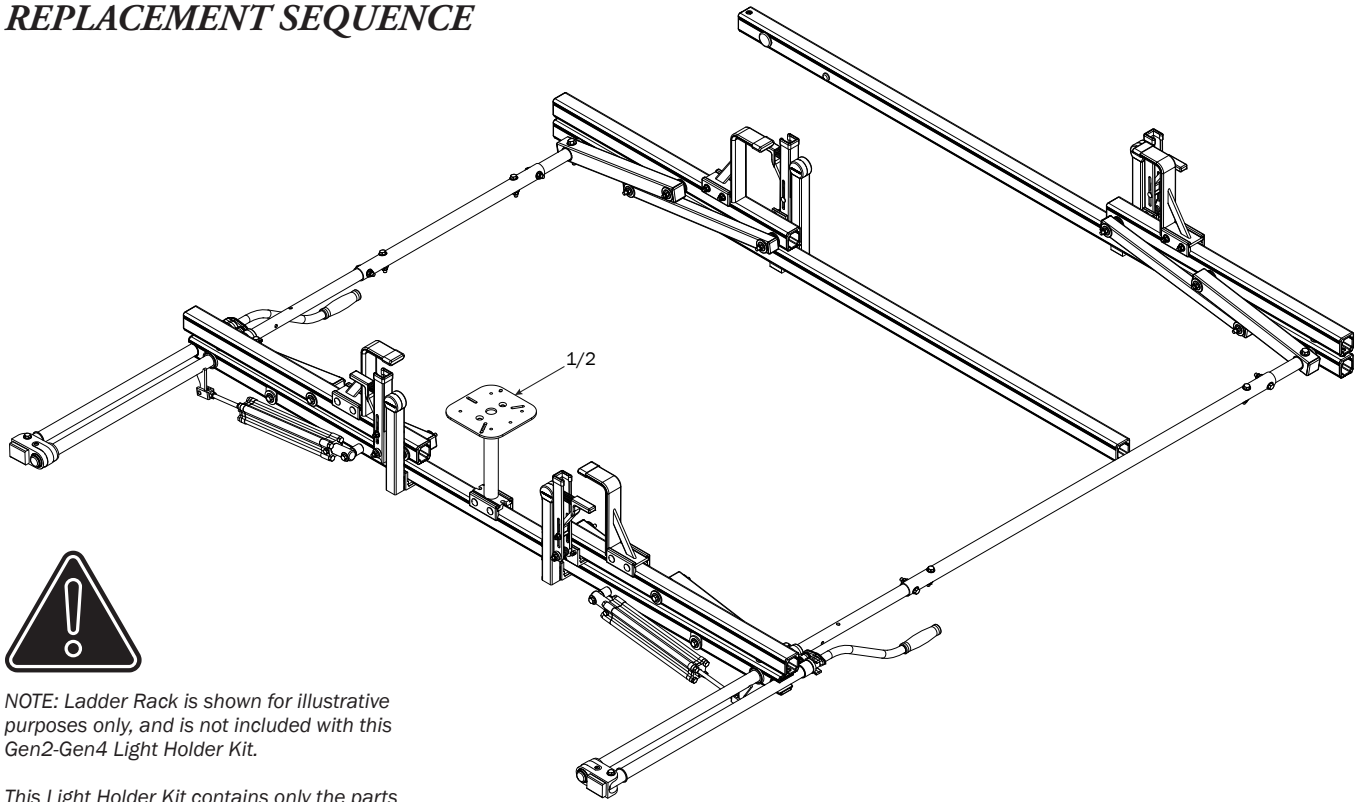

NOTE: Ladder Rack is shown for illustrative purposes only, and is not included with this Gen2-Gen4 Light Holder Kit.

This Light Holder Kit contains only the parts needed to repair, replace, or retrofit one Crossbar. Order an additional kit for the other Crossbar to add an additional accessory light.

LIGHT HOLDER REMOVAL

- 1.1** Remove and discard the affected Light Holder Carriage Bolt, Flat Washer, and Lock Nut.

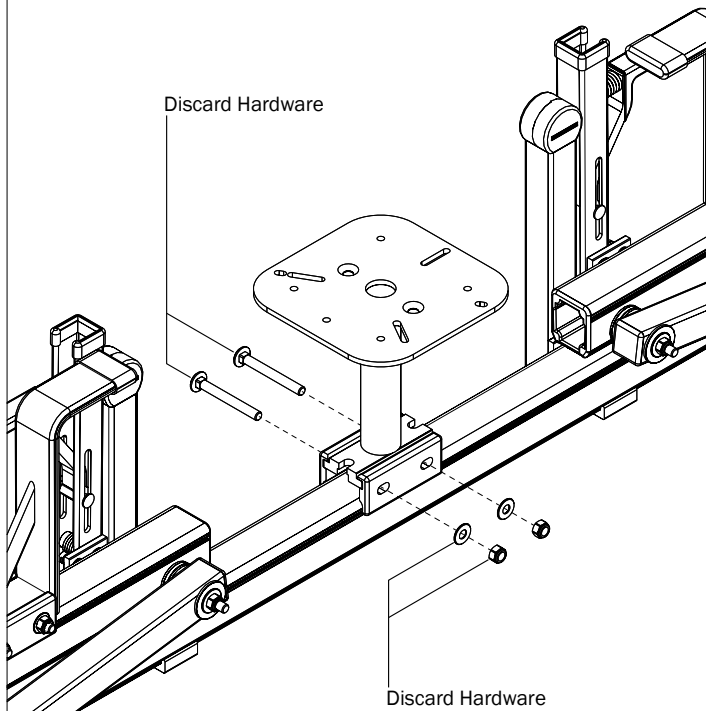

- 1.2** Remove and discard the affected Light Holder Clamps, and Light Holder

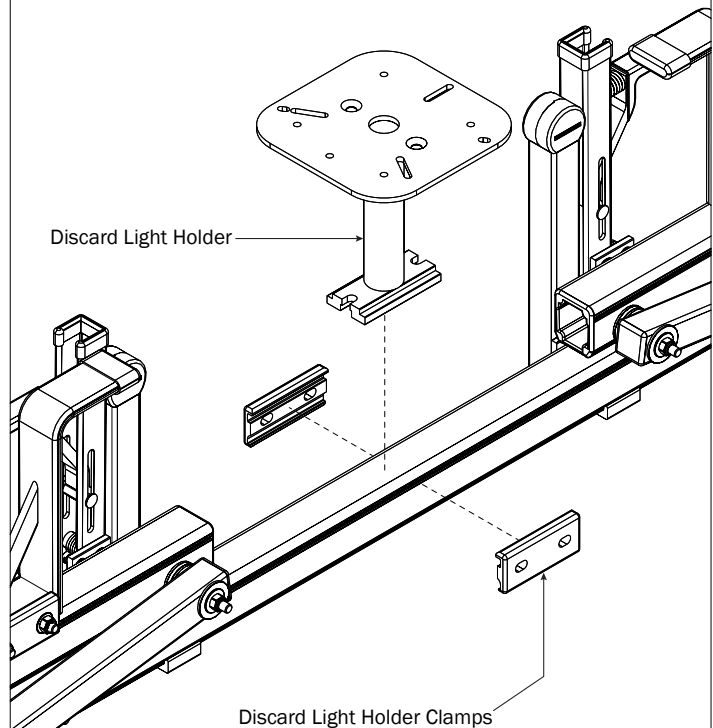

LIGHT HOLDER INSTALLATION

- 2.1** Assemble the Light Holder Clamps onto the Crossbar using the provided hardware shown below. Do not tighten until Step 2.6.

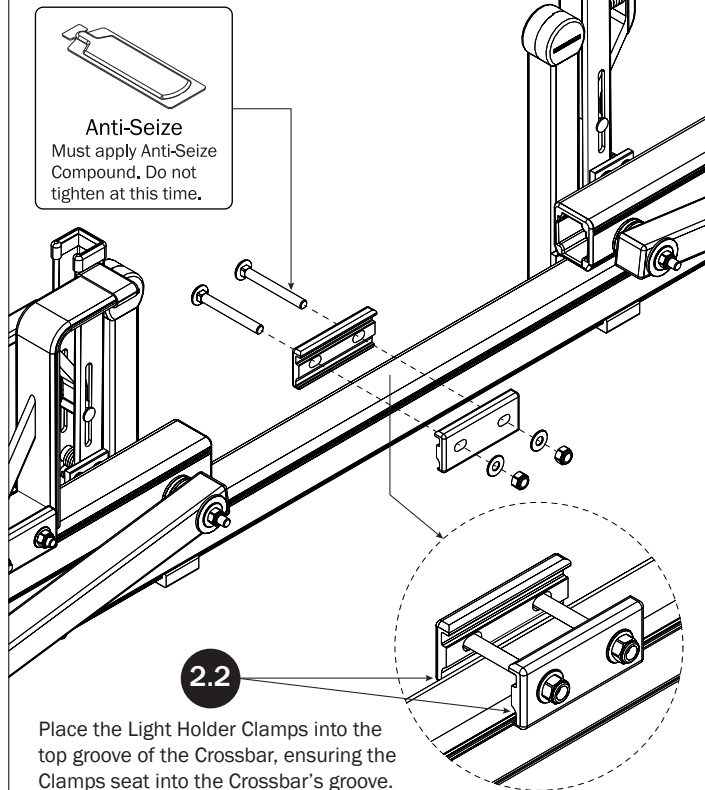

- 2.3** Place the Light Holder between the Clamps, and ensure the Holder fully engages the Clamp's top groove.

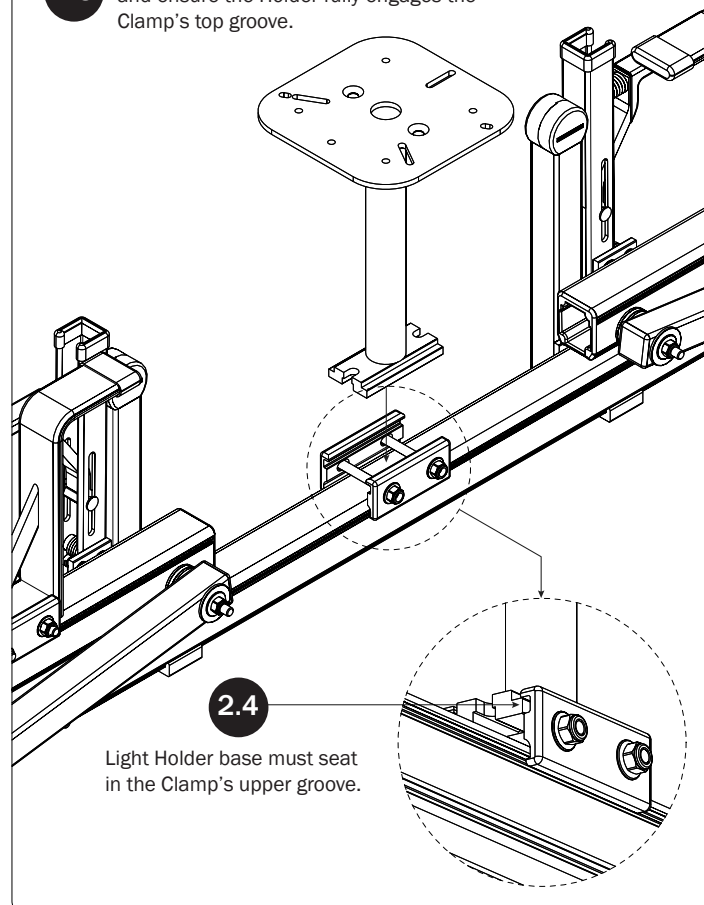

- 2.5** Center the Accessory Light Holder evenly between the Uppers if mounted to a Rotation-Rotation rack model as seen in Figure 1. If using on a rack equipped with only one rotation, mount a minimum distance of 1.00" to prevent interference or binding with the Rotation Upper as seen on Figure 2.

Figure 1

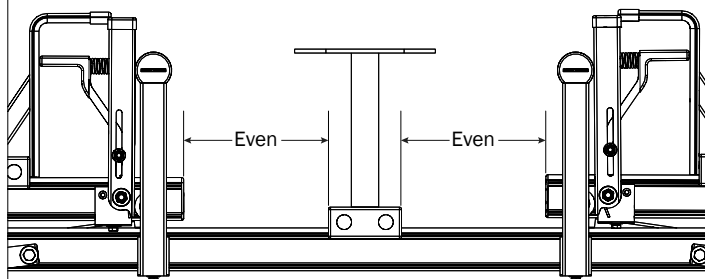
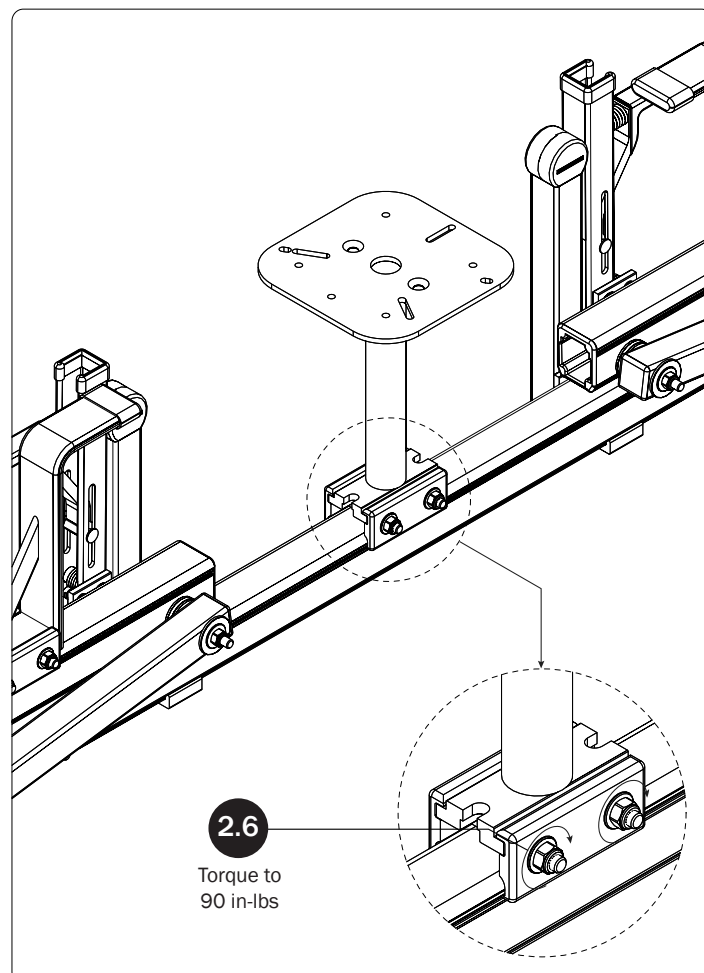
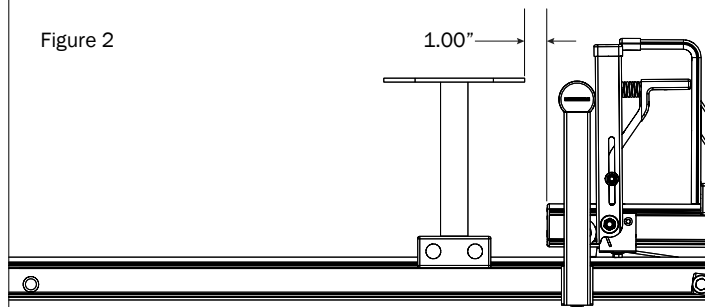
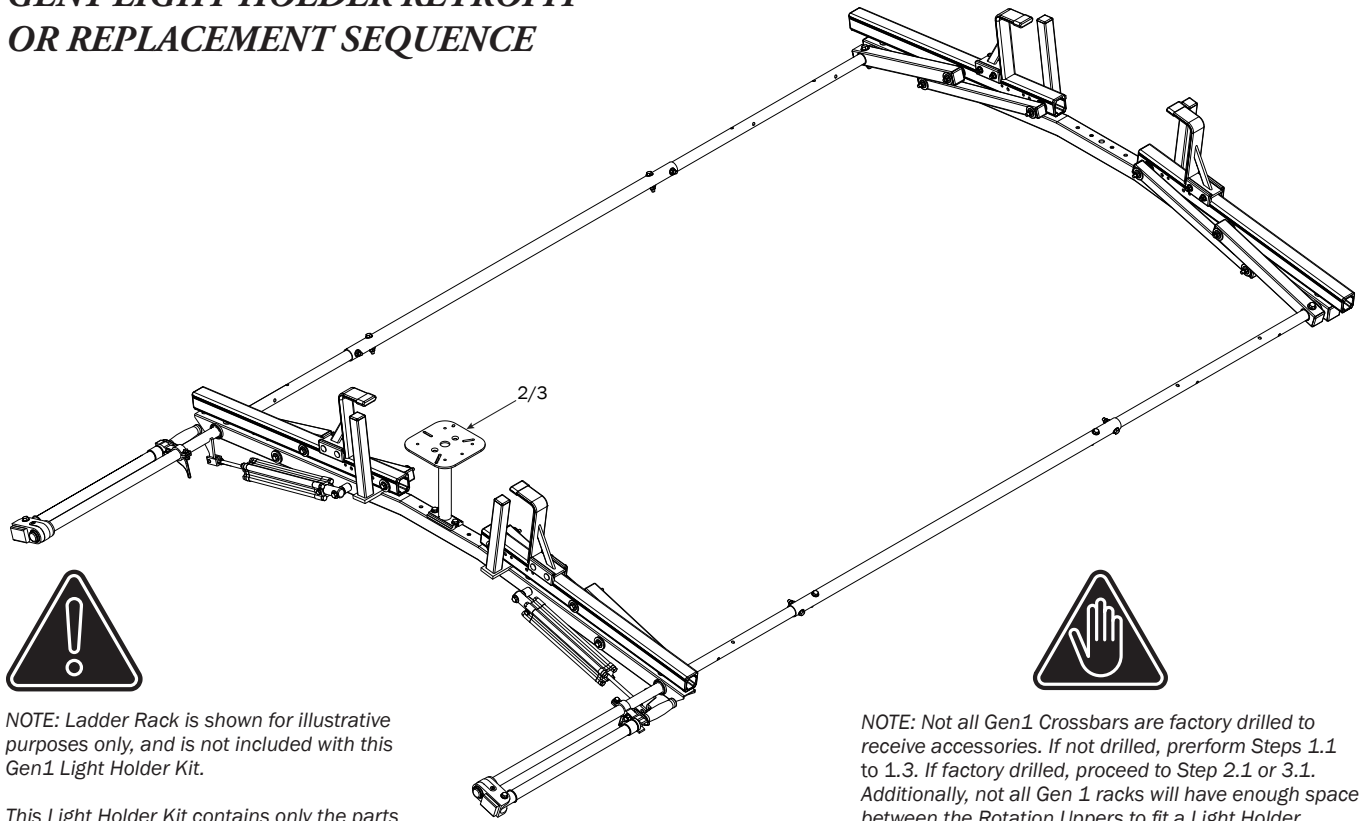

Figure 2



GEN1 LIGHT HOLDER RETROFIT OR REPLACEMENT SEQUENCE



NOTE: Ladder Rack is shown for illustrative purposes only, and is not included with this Gen1 Light Holder Kit.

This Light Holder Kit contains only the parts needed to repair, replace, or retrofit one Crossbar. Order an additional kit for the other Crossbar to add an additional accessory light.

NOTE: Not all Gen1 Crossbars are factory drilled to receive accessories. If not drilled, perform Steps 1.1 to 1.3. If factory drilled, proceed to Step 2.1 or 3.1. Additionally, not all Gen 1 racks will have enough space between the Rotation Uppers to fit a Light Holder. Measure prior to drilling to ensure there will be no Rotation interference. A minimum of 1.00" is required between the Uppers and the Light Holder Mounting.

CROSSBAR PREPARATION-RETROFIT

- 1.1** Find the center of the top of the Crossbar between the inner bends. Using a grease pencil, mark the center, then measure out 1.50" to the left and right of that center mark and mark again using the grease pencil. The marked distances will measure 3.00" across as shown below.

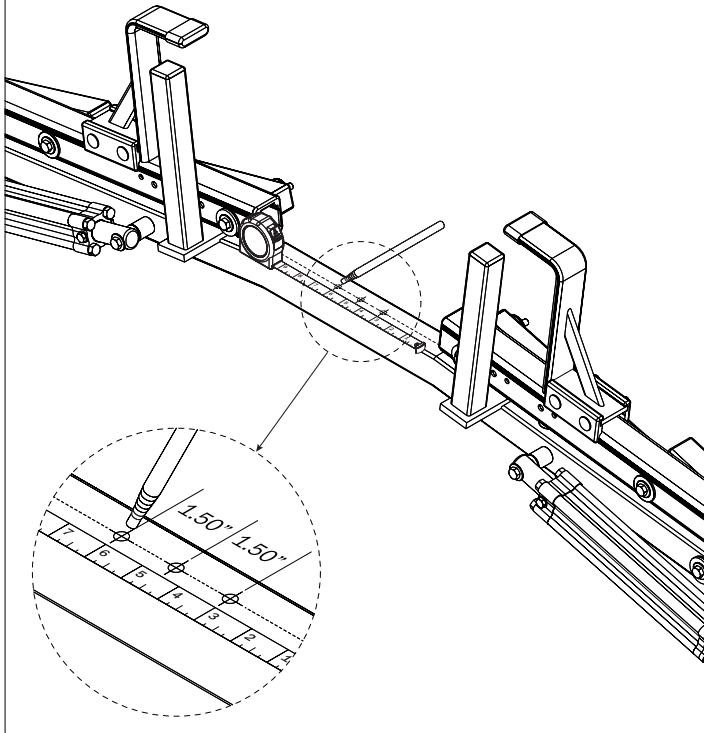

- 1.2** Prior to drilling, mark a center line along the length of the Crossbar to ensure the holes are correctly centered.

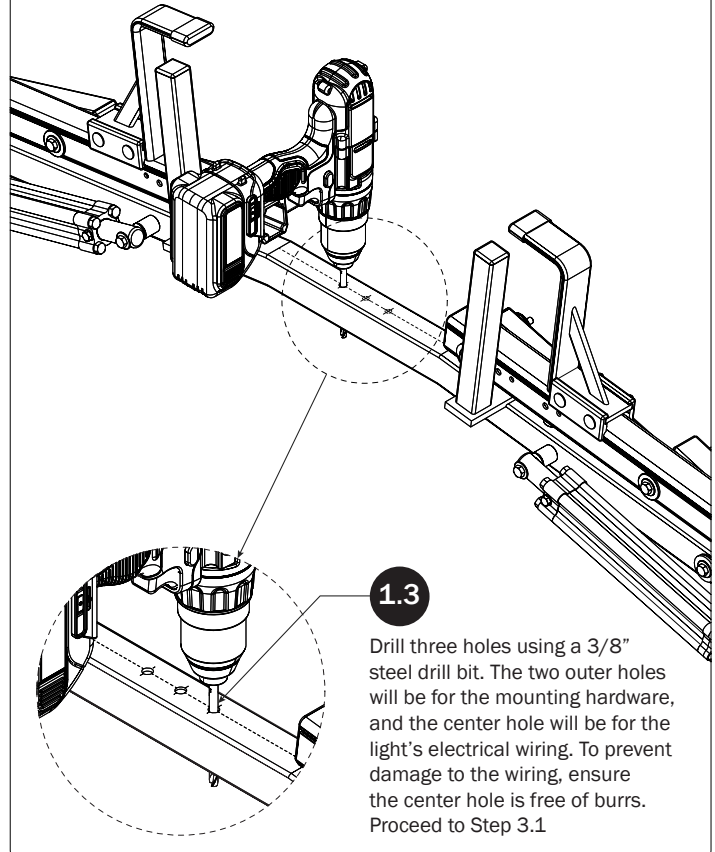

- 1.3** Drill three holes using a 3/8" steel drill bit. The two outer holes will be for the mounting hardware, and the center hole will be for the light's electrical wiring. To prevent damage to the wiring, ensure the center hole is free of burrs. Proceed to Step 3.1

LIGHT HOLDER REPLACE

2.1 Remove and discard the affected Light Holder Flat Washers, and Lock Nuts.

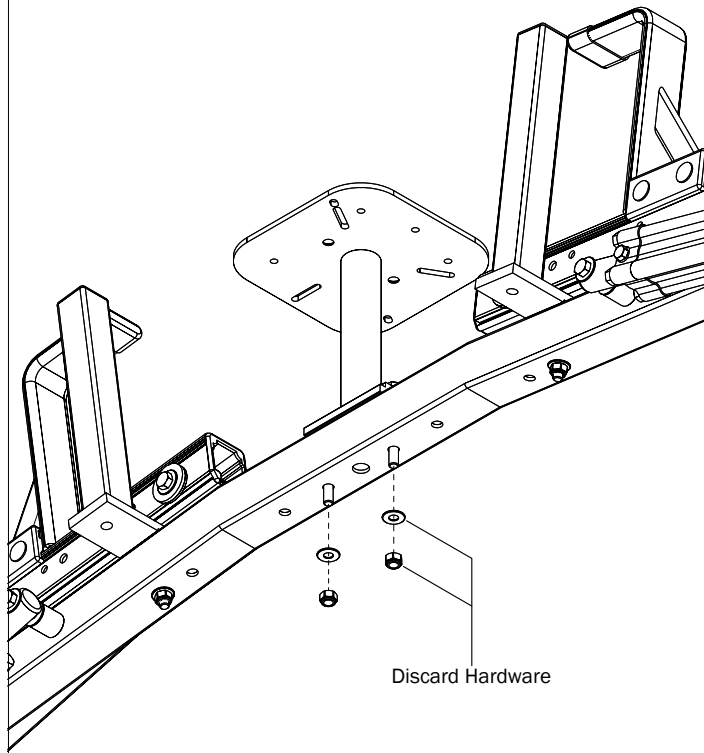

2.2 Remove and discard the affected Light Holder Clamps, and Light Holder

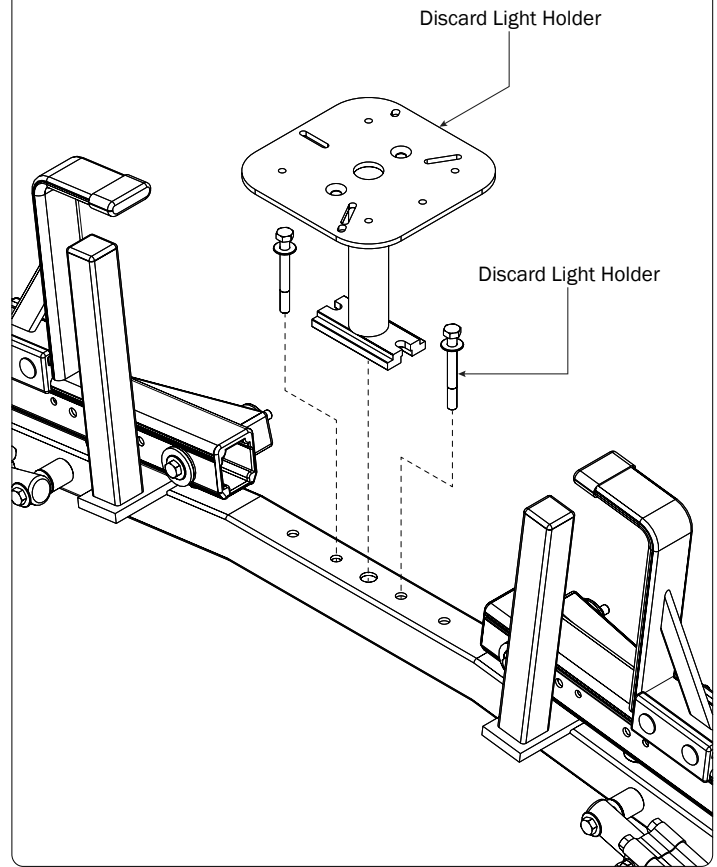

LIGHT HOLDER INSTALLATION

3.1 Assemble the Light Holder onto the Crossbar using the hardware shown below. Do not tighten until Step 3.3.

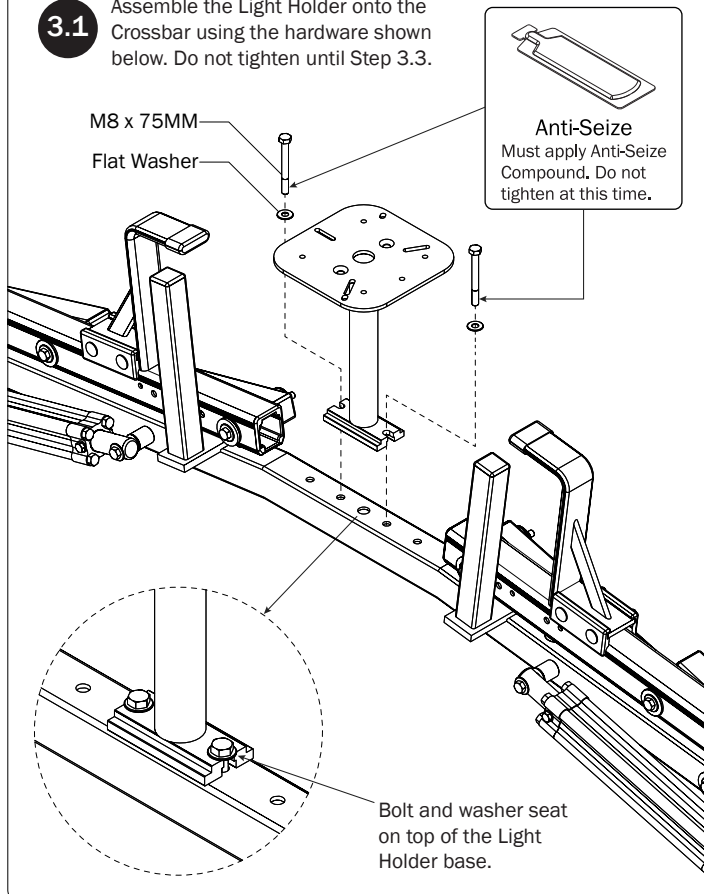

3.2 Complete the assembly of the Light Holder onto the Crossbar using the hardware shown below.

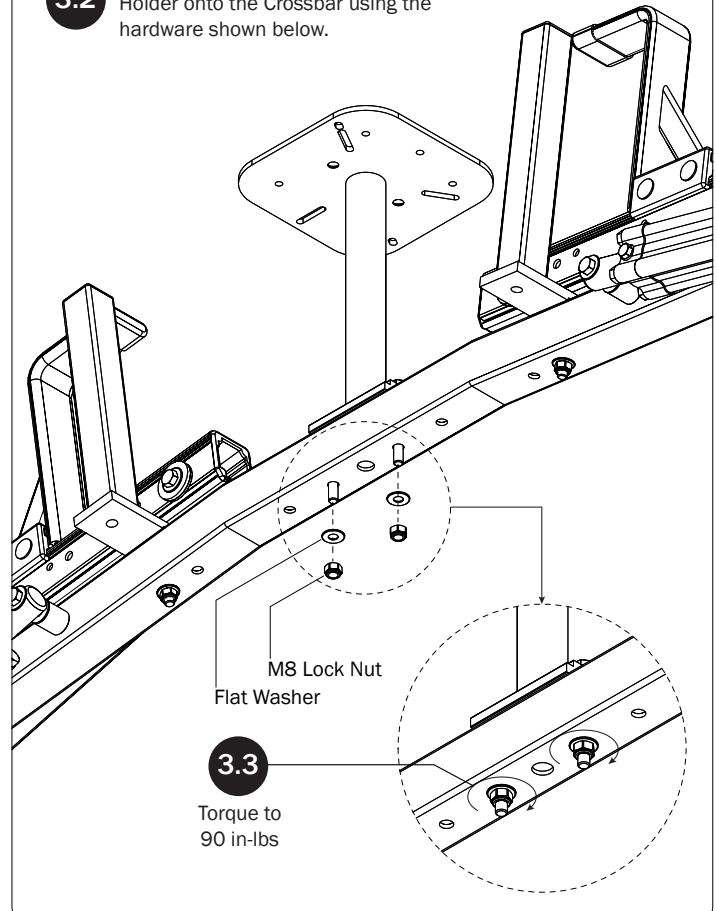

Page Intentionally Left Blank

